

# **Video Camera Recorder Hi8**

---

## **Operation Manual**

Before operating the unit, please read this manual thoroughly and retain it for future reference.

## **Owner's Record**

The model and serial numbers are located on the bottom. Record the serial number in the space provided below. Refer to them whenever you call upon your Sony dealer regarding this product.

Model No. CCD-TR \_\_\_\_\_  
Serial No. \_\_\_\_\_

Model No. AC-V \_\_\_\_\_  
Serial No. \_\_\_\_\_

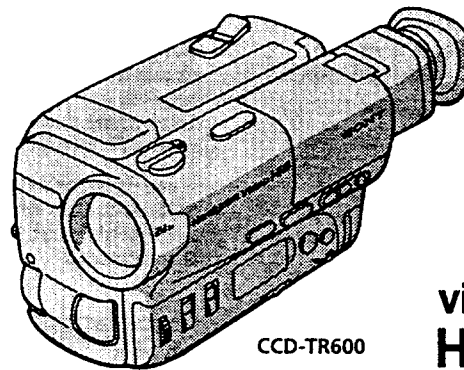

CCD-TR600

**video Hi8  
Handycam**

**CCD-TR100/TR600**

## Welcome to Video Hi8

Congratulations on your purchase of this Sony Handycam® camcorder. With your Handycam you can capture life's precious moments with superior picture and sound quality. Your Handycam is loaded with advanced features, but at the same time it is very easy to use. You will soon be producing home video that you can enjoy for years to come.

### WARNING

**To prevent fire or shock hazard, do not expose the unit to rain or moisture.**

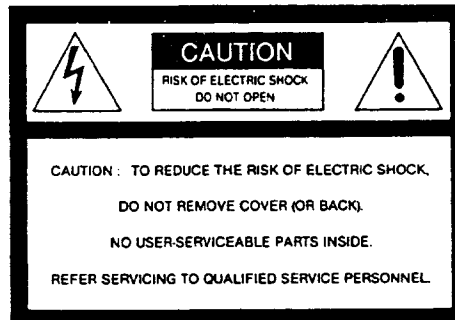

This symbol is intended to alert the user to the presence of uninsulated "dangerous voltage" within the product's enclosure that may be of sufficient magnitude to constitute a risk of electric shock to persons.



This symbol is intended to alert the user to the presence of important operating and maintenance (servicing) instructions in the literature accompanying the appliance.

### RECYCLING NICKEL-CADMIUM BATTERIES



**NICKEL-CADMIUM BATTERY. MUST BE DISPOSED OF PROPERLY.**

**Ni-Cd** Nickel-Cadmium batteries are recyclable. You can help preserve our environment by returning your unwanted batteries to your nearest Sony Service Center or Factory Service Center for collection, recycling or proper disposal.

**Note:** In some areas the disposal of nickel-cadmium batteries in household or business trash may be prohibited.

For the Sony Service Center nearest you call 1-800-222-SONY (United States only)  
For the Factory Service Center nearest you call 416-499-SONY (Canada only)

**Caution: Do not handle damaged or leaking nickel-cadmium batteries.**

### For Customers in the U.S.A.

#### Note:

This equipment has been tested and found comply with the limits for a Class B digital device, pursuant to Part 15 of the FCC Rule. These limits are designed to provide reasonable protection against harmful interference in a residential installation. The equipment generates, uses, and can radiate radio frequency energy and, if not installed and used in accordance with the instructions may cause harmful interference to radio communications. However, there is no guarantee that interference will not occur in particular installation. If this equipment do cause harmful interference to radio or television reception, which can be determined by turning the equipment off and on, the user is encouraged to try to correct the interference by one or more of the following measures:

- Reorient or relocate the receiving antenna
- Increase the separation between the equipment and receiver.
- Connect the equipment into an outlet on a circuit different from that to which the receiver is connected.
- Consult the dealer or an experienced radio/TV technician for help.

You are cautioned that any changes or modifications not expressly approved in the manual could void your authority to operate this equipment.

### For Customers in CANADA

#### CAUTION

TO PREVENT ELECTRIC SHOCK, DO NOT USE THIS POLARIZED AC PLUG WITH / EXTENSION CORD, RECEPTACLE OR OTHER OUTLET UNLESS THE BLADES CAN BE FULLY INSERTED TO PREVENT BLADE EXPOSURE.

# Table of Contents

## Before You Begin

- Checking Your Model Number 4
- Checking Supplied Accessories 5

## Getting Started

- Charging and Installing the Battery Pack 6
- Inserting a Cassette 9

## Basic Operations

- Camera Recording 10
  - Using the Zoom Feature 12
- Hints for Better Shooting 13
- Checking the Recorded Picture 14
- Connections for Playback 15
- Playing Back a Tape 16

## Advanced Operations

- Using Alternative Power Sources 18
  - Using House Current 18
- Recording with the Date or Time 21
- Using the PROGRAM AE Function 22
- Fade-in and Fade-out 23
- Focusing Manually 24
- Releasing the STEADY SHOT Function (CCD-TR600 only) 25
- Enjoying Picture Effect 26
- Adjusting the Exposure 28
- Shooting Scenery in Several Short Takes 29
- Changing the Mode Settings 30
- Editing onto Another Tape 32
- Recording from a VCR or TV 33

## Additional Information

- Changing the Lithium Battery 34
- Resetting the Date or Time 35
- Playback Modes 36
- Tips for Using the Battery Pack 36
- Maintenance Information and Precautions 39
- Using Your Camcorder Abroad 42
- Trouble Check 43
- Specifications 46
- Identifying the Parts 47
  - Remote Commander 50
- Warning Indicators 53
- Index 54

## Before You Begin

# Checking Your Model Number

The instructions in this manual are for the two models listed below. Before you start reading this manual and operating the unit, check your model number by looking at the bottom of your camcorder. The CCD-TR600 is the model used for illustration purposes. Otherwise, the model name is indicated in the illustrations. Any differences in operation are clearly indicated in the text, for example, "CCD-TR100 only."

As you read through this manual, buttons and settings on the camcorder are shown in capital letters. e.g. Set the POWER switch to CAMERA.

### Types of differences

Model number	Steady Shot	Picture Effect	Viewfinder		Zoom (x)
			Monochrome	Color	
CCD-TR100*		5 modes	•		12
CCD-TR600	•	7 modes		•	24 (Digital)

\* CCD-TR100 is the U. S. A. model.

### Note on TV Color Systems

TV color systems differ from country to country. To view your recordings on a TV, you need an NTSC system-based TV. When you want to use a PAL-M system-based TV, you will need an NTSC/PAL-M transcoder (as this is an NTSC system based camcorder). Please check the list on page 42 to find out the TV color system used in your country.

### Precaution on Copyright

Television programs, films, video tapes, and other materials may be copyrighted. Unauthorized recording of such materials may be contrary to the provision of the copyright laws.

### Precautions on Camcorder Care

- Do not let sand get into the camcorder. When you use the camcorder on a sandy beach or dusty place, protect it from the sand or dust. Sand or dust may cause the unit to malfunction and sometimes the malfunction cannot be repaired [a].
- Do not let the camcorder get wet. Keep the camcorder away from rain and sea water. Letting the camcorder get wet may cause the unit to malfunction and sometimes the malfunction cannot be repaired [b].
- Never leave the camcorder exposed to temperatures above 140 °F (60 °C), such as in a car parked in the sun or under direct sunlight [c].

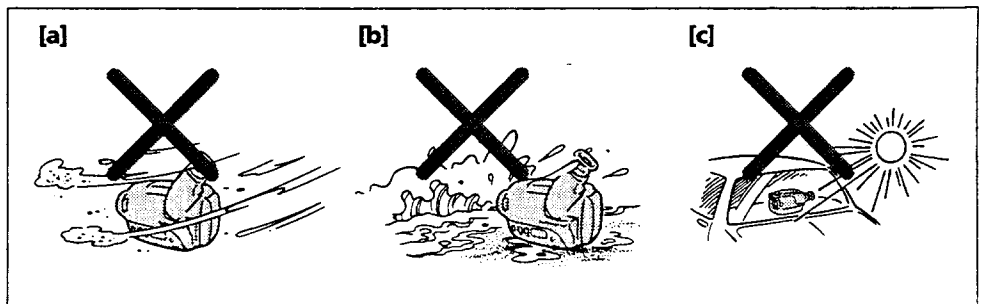

## Checking Supplied Accessories

Check that the following accessories are supplied with your camcorder.

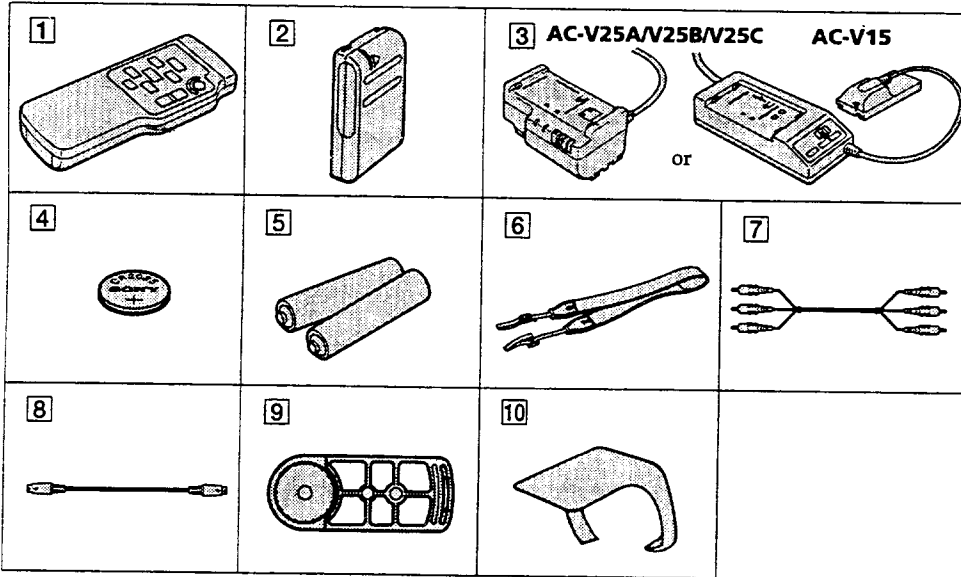

Before You Begin

- 1 Wireless Remote Commander (1) (p. 50)
- 2 NP-55 Battery pack (1) (p. 6)
- 3 AC-V25A/V25B/V25C/V15 AC power adaptor (1) (p. 6, 18)
- 4 CR2025 Lithium Battery (1) (p. 34)  
(The lithium battery is already installed in your camcorder.)
- 5 Size AA (R6) battery for Remote Commander (2) (p. 50)
- 6 Shoulder strap (1) (p. 49)
- 7 A/V connecting cable (1) (p. 15)
- 8 S video connecting cable (1) (p. 15)
- 9 Tripod adaptor (1) (p. 13)
- 10 Shading cover (CCD-TR600 only) (1)

Contents of the recording cannot be compensated if recording or playback is not made due to a malfunction of the camcorder, video tape, etc.

## Getting Started

# Charging and Installing the Battery Pack

Before using your camcorder, you first need to charge and install the battery pack. To charge the battery pack, use the supplied AC power adaptor.

## Charging the Battery Pack

Charge the battery pack on a flat surface without vibration.

- (1) Connect the power cord to a wall outlet.
- (2) Align the right side of the battery pack with the line on the AC power adaptor, then slide the battery pack in the direction of the arrow.

- (3) Set the selector to CHARGE. The CHARGE lamp (orange) lights up. Charging begins. When charging is completed, the CHARGE lamp goes out. Set the selector to the center position (AC-V25A/V25B/V25C only) and unplug the unit from the wall outlet. Then remove the battery pack and install it on the camcorder.

### AC-V25A/V25B/V25C

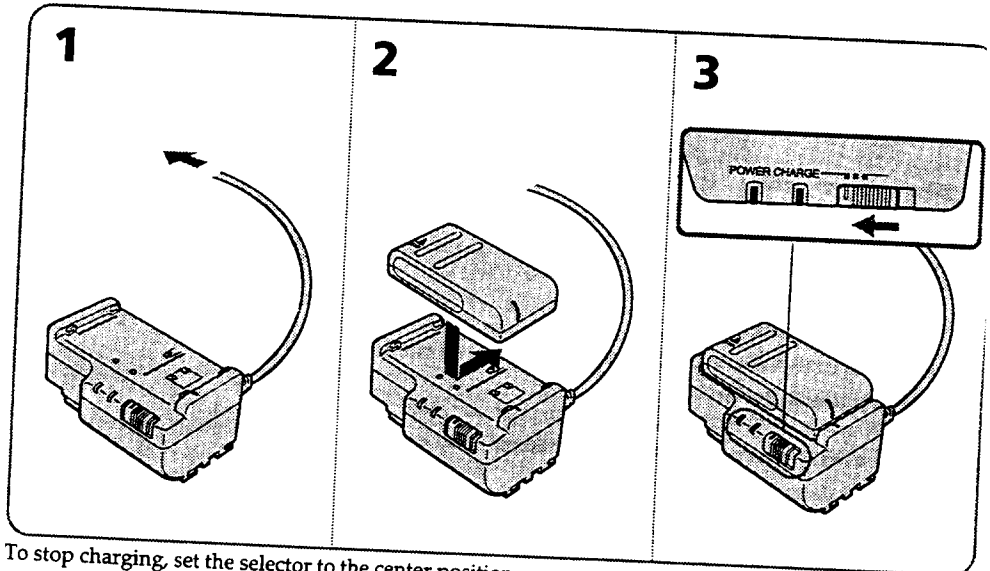

To stop charging, set the selector to the center position.

### AC-V15

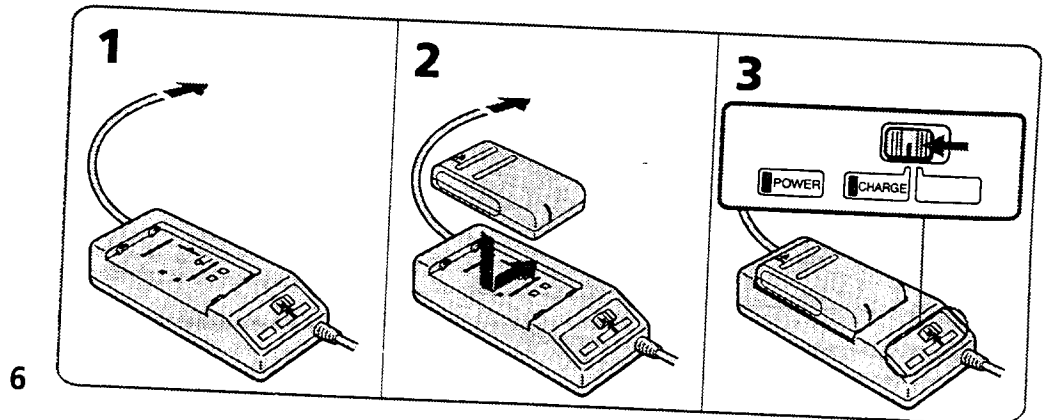

## Charging Time

Battery pack	NP-55 (supplied)	NP-80 NP-80D	NP-77H	NP-68 NP-66H	NP-C65	NP-60D
Charging time*	70	190	170	125	105	90

\* Approximate minutes to charge an empty battery pack using the supplied AC power adaptor.  
(Lower temperatures require a longer charging time.)

## Battery Life

### CCD-TR100

Battery pack	NP-55 (supplied)	NP-80 NP-80D	NP-77H	NP-68 NP-66H	NP-C65	NP-60D
Typical recording time**	30	75	75	55	40	40
Continuous recording time***	55	150	145	105	80	75

### CCD-TR600

Battery pack	NP-55 (supplied)	NP-80 NP-80D	NP-77H	NP-68 NP-66H	NP-C65	NP-60D
Typical recording time**	25	70	70	50	40	35
Continuous recording time***	50	140	135	100	75	65

\*\* Approximate minutes when recording while you repeat recording start/stop or zooming and turning the power on/off. The actual battery life may be shorter.

\*\*\* Approximate continuous recording time indoors.

## Important!

### Use the battery completely before re-charging!

Before you recharge the battery pack, make sure the battery has been used up (discharged) completely. Repeated charging while some capacity remains causes a lowering of battery capacity. However, the original battery capacity can be recovered if you use the battery completely and charge it fully again.

To use up the battery, remove the cassette and turn the POWER switch to CAMERA with the battery pack attached, and leave the camcorder until the  indicator flashes and the red lamp flashes rapidly in the viewfinder.

Getting Started

the next page for further information.

## Charging and Installing the Battery Pack

### To Remove the Battery Pack

Slide the battery pack in the direction of the arrow.

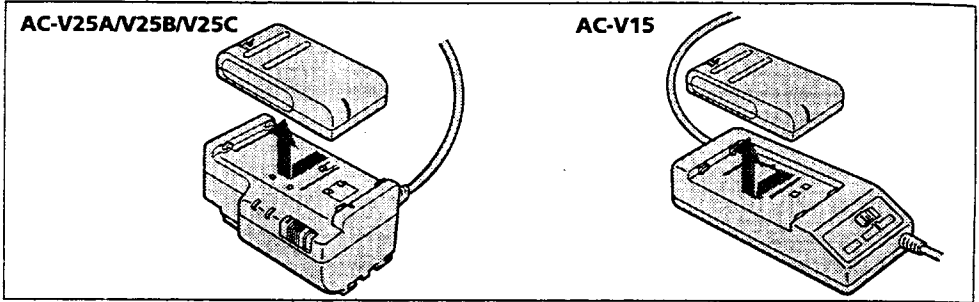

### Notes on charging the battery pack

- The POWER lamp will remain lit for a while even if the battery pack is removed and the power cord is unplugged after charging the battery pack. This is normal.
- If the POWER lamp does not light, set the selector to the center position (AC-V25A/V25B/V25C only) and disconnect the power cord. After about one minute, reconnect the power cord and set the selector to CHARGE again.
- You cannot operate the camcorder using the AC power adaptor while charging the battery pack.

### Installing the Battery Pack

- (1) Lift up the viewfinder.
- (2) Align the right side of the battery pack with the white line on the camcorder, and slide the battery pack to the right.

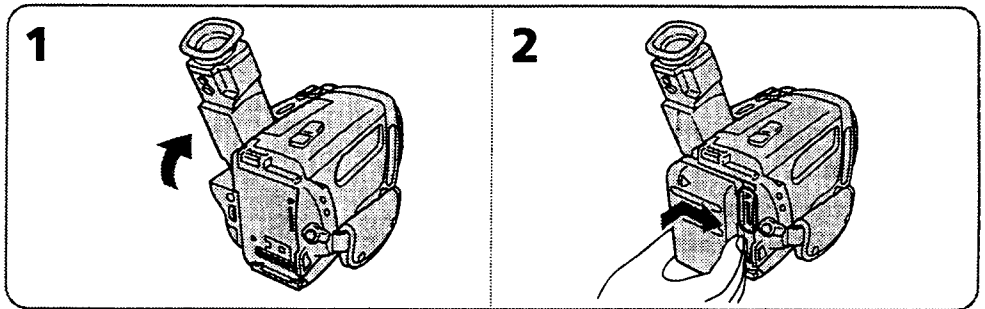

### To Remove the Battery Pack

- (1) Lift up the viewfinder.
- (2) While pressing BATT, slide the battery pack to the left.

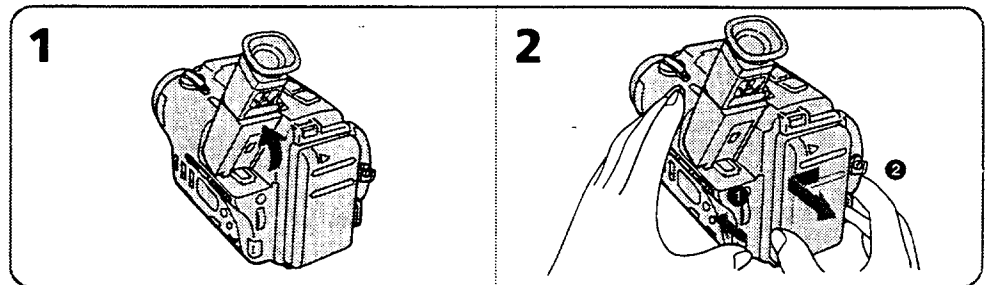



# Inserting a Cassette

Make sure that the power source is installed.

When you want to record in the Hi8 system, use Hi8 video cassette **Hi8**.

- (1) While sliding the release knob in the direction of the arrow, lift up the lid.
- (2) Press EJECT. The cassette compartment automatically lifts up and opens.
- (3) Insert a cassette with the window facing out.
- (4) Close the cassette compartment by pressing the "PUSH" mark on the cassette compartment. The cassette compartment automatically goes down.
- (5) Close the lid.

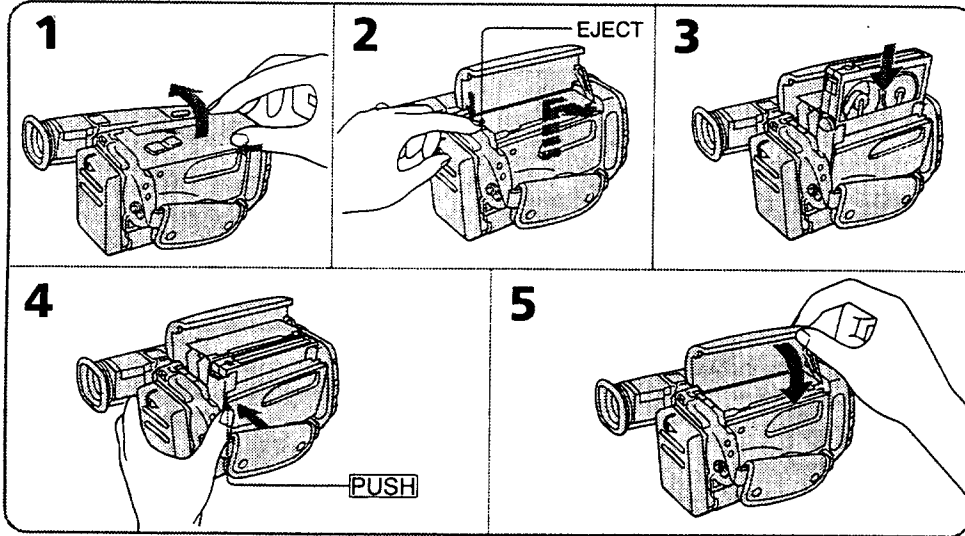



Getting Started

## To Eject the Cassette

While sliding the release knob in the direction of the arrow, lift up the lid of the cassette holder and press EJECT.

## To Prevent Accidental Erasure

Slide the tab on the cassette to expose the red mark. If you try to record with the red mark exposed, the  and  indicators flash in the viewfinder, and you cannot record.

To re-record on this tape, slide the tab back out covering the red mark.

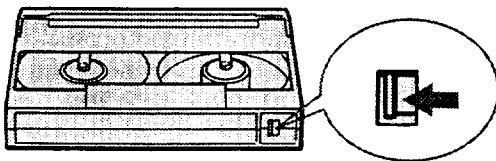

## Basic Operations

# Camera Recording

Make sure that the power source is installed and a cassette is inserted. When you use the camcorder for the first time, reset the date and time before you start recording (p. 35). The date is automatically recorded for 10 seconds after you start recording (AUTO DATE feature). This feature works only once a day.

Before you record one-time events, you may want to make a trial recording to make sure that the camcorder is working correctly.

- (1) While pressing the small green button on the POWER switch, turn it to CAMERA.
- (2) Turn STANDBY up.
- (3) Press START/STOP. The camcorder starts recording. The "REC" indicator appears and the red lamp lights up in the viewfinder. The camera recording/battery lamp also lights up.

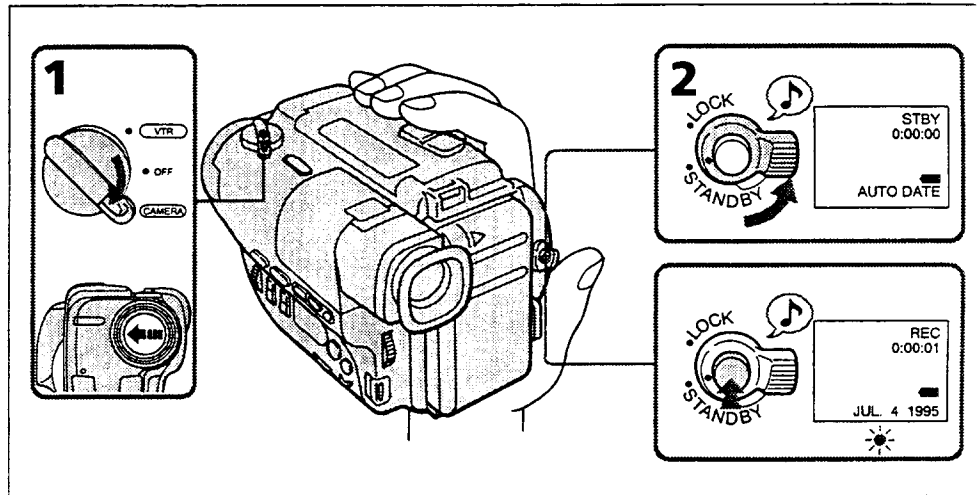

### To Stop Recording Momentarily [a]

Press START/STOP again. The "STBY" indicator appears in the viewfinder (Standby mode).

### To Finish Recording [b]

Press START/STOP again. Turn STANDBY down and turn the POWER switch to OFF. Then, eject the cassette (p. 9) and remove the battery pack (p. 8).

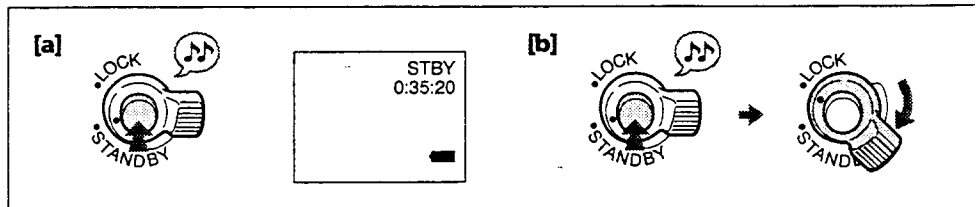

### To Focus the Viewfinder Lens

If you cannot see the indicators in the viewfinder clearly, or after someone else has used the camcorder, focus the viewfinder lens.

When using a monochrome viewfinder, turn the viewfinder lens adjustment ring so that the indicators in the viewfinder come into sharp focus [a]. When using a color viewfinder, move the viewfinder lens adjustment lever so that the indicators in the viewfinder come into sharp focus [b].

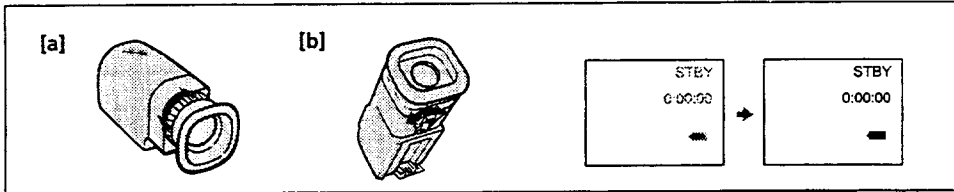

### Note on Standby mode

If you leave the camcorder in Standby mode for 5 minutes while the cassette is inserted, the camcorder turns off automatically. This prevents wearing down the battery and wearing out the tape. To resume Standby mode, turn STANDBY down once and turn it up again. To start recording, press START/STOP.

### Note on recording

When you record from the beginning of a tape, run the tape for about 15 seconds before starting the actual recording. This will ensure that you won't miss any start-up scenes when you play back the tape. You can record tapes in SP (standard play) mode only.

### Note on the tape counter

The tape counter indicates the recording or playback time. Use it as a guide. There will be a time lag of several seconds from the actual time. To set the counter to zero, press COUNTER RESET.

### Note on beep sound

As indicated with  $\mathcal{P}$  in the illustrations, a beep sounds when you turn the power on or when you start recording and two beeps sound when you stop recording, confirming the operation. Several beeps also sound as a warning of any unusual condition of the camcorder (p. 53).

Note that the beep sound is not recorded on the tape. If you do not want to hear the beep sound, select "OFF" in the menu system.

### Note on the AUTO DATE feature

The clock is set to the East Coast Standard Time at the factory, but you can reset the clock in the menu system (p. 35). You can change the AUTO DATE settings by selecting ON or OFF in the menu system. The AUTO DATE feature works once a day. However, the date may automatically appear more than once a day when:

- you reset the date and time.
- you eject and insert the tape again.
- you stop recording within 10 seconds.
- you set AUTO DATE to OFF once and set to ON again in the menu system.

### When moving from indoors to outdoors (or vice versa)

Turn STANDBY up and point the camcorder at a white object for about 15 seconds so that the white balance is properly adjusted.

See the next page for further information.

## Camera Recording

### Using the Zoom Feature

Zooming is a recording technique that lets you change the size of the subject in the scene.

For more professional-looking recordings, use the zoom function sparingly.

"T" side: for telephoto (subject appears closer)

"W" side: for wide-angle (subject appears farther away)

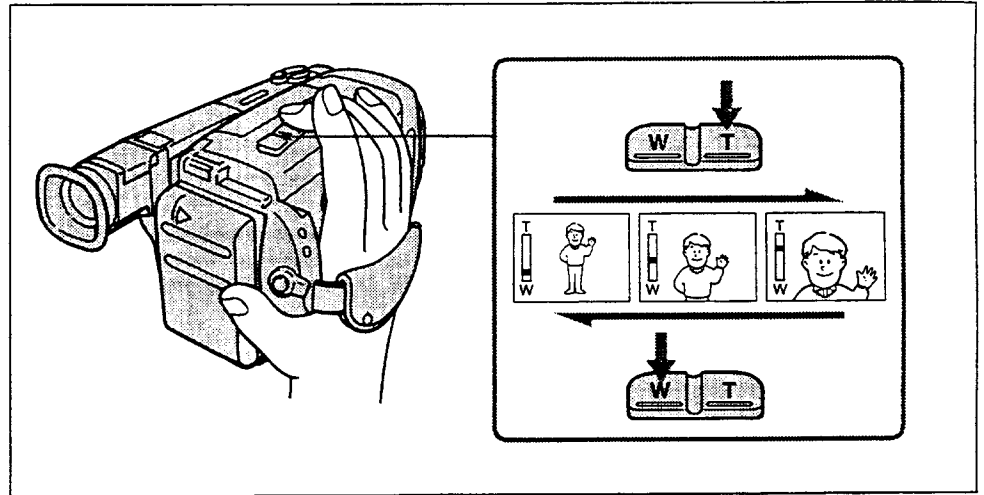

### Zooming Speed (Dual speed zooming)

Press the power zoom button firmly for a high-speed zoom, press it softly for a relatively slow zoom.

### When you shoot a subject using a telephoto zoom

If you cannot get a sharp focus while in extreme telephoto zoom, press the "W" side of the power zoom button until the focus is sharp. You can shoot a subject that is at least about 3 1/4 feet (100 cm) away from the lens surface in the telephoto position, or about 1/2 inches (1 cm) in the wide-angle position.

### Notes on Digital Zoom (CCD-TR600 only)

- More than 12x zoom is performed digitally, and the picture quality deteriorates as you go toward the T side. If you do not want to use the digital zoom, set the D ZOOM function to OFF in the menu system.
- The horizontal bar in the power zoom indicator separates the digital zooming zone (above the bar [a]) and the optical zooming zone (under the bar [b]). If you set the D ZOOM function to OFF, the part above the bar disappears.

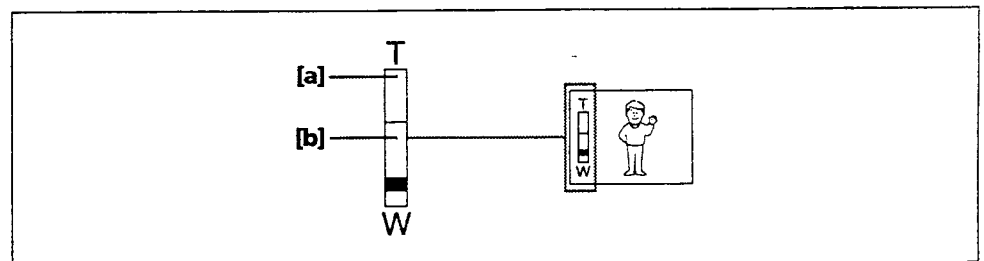

## Hints for Better Shooting

For hand-held shots, you'll get better results by holding the camcorder according to the following suggestions:

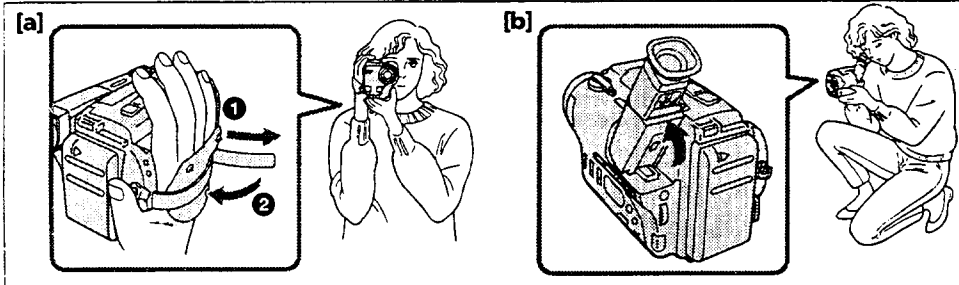

- Hold the camcorder firmly and secure it with the grip strap so that you can easily manipulate the controls with your thumb [a].
- Place your right elbow against your side.
- Place your left hand under the camcorder to support it.
- Place your eye firmly against the viewfinder eyecup.
- Use the viewfinder frame as a guide to determine the horizontal plane.
- You can also record in a low position to get an interesting recording angle. Lift the viewfinder up for recording from a low position [b].

### Place the camcorder on a flat surface or use a tripod

Try placing the camcorder on a table top or any other flat surface of suitable height. If you have a tripod for a still camera, you can also use it with the camcorder (p. 48).

If the camcorder is difficult to balance on a tripod, use the supplied tripod adaptor. Attach the tripod adaptor to the camcorder by turning the screw [c]. The adaptor has a screw hole for a tripod. Do not leave the tripod adaptor on the camcorder if the camcorder is not mounted on a tripod.

When attaching a non-Sony tripod, make sure that the length of the tripod screw is less than 9/32 inches (6.5 mm). Otherwise, the screw may damage the inner parts of the camcorder.

### Cautions on the viewfinder

- Do not pick up the camcorder by the viewfinder [d].
- Do not place the camcorder so as to point the viewfinder toward the sun. The inside of the viewfinder may be deformed. Be careful when placing the camcorder under sunlight or by the window [e].

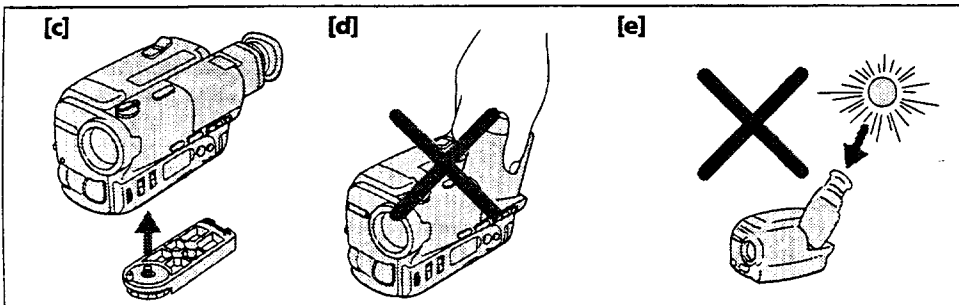

## Checking the Recorded Picture

Using EDITSEARCH, you can review the last recorded scene or check the recorded picture in the viewfinder.

- (1) While pressing the small green button on the POWER switch, turn it to CAMERA.
- (2) Turn STANDBY up.
- (3) Press the - (⊖) side of EDITSEARCH momentarily; the last few seconds of the recorded portion plays back (Rec Review).  
Hold down the - side of EDITSEARCH until the camcorder goes back to the scene you want. The last recorded portion is played back. To go forward, hold down the + side (Edit Search).

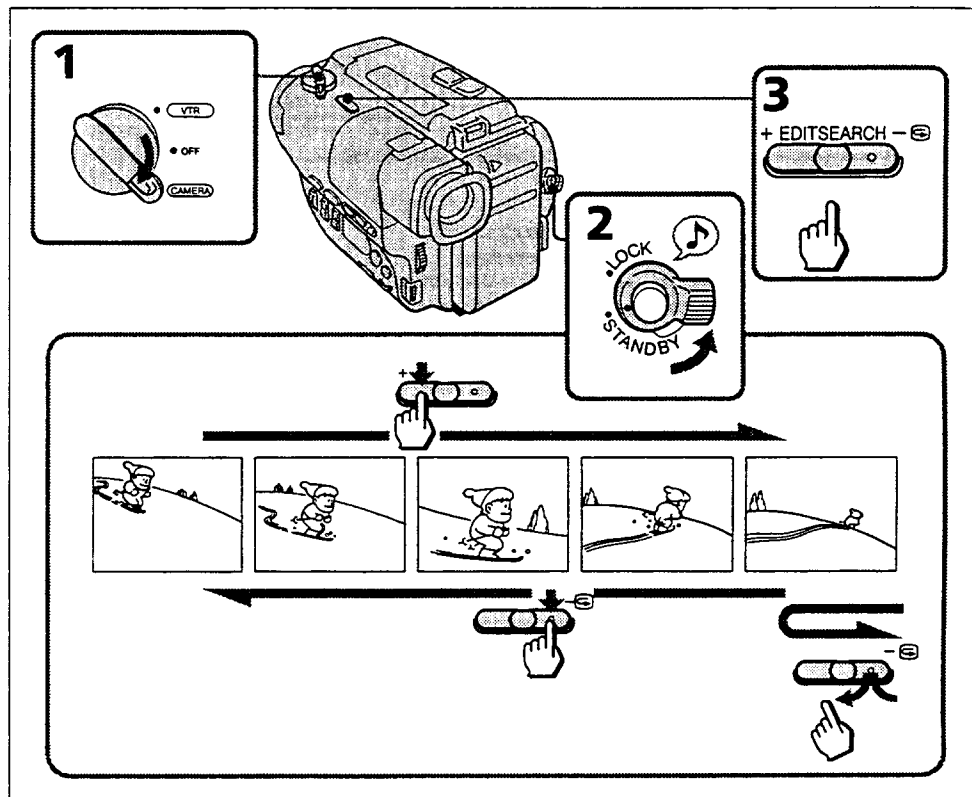

### To Stop Playback

Release EDITSEARCH.

### To Begin Re-recording

Press START/STOP. Re-recording begins from the point you released EDITSEARCH. Provided you do not eject the tape, the transition between the last scene you recorded and the next scene you record will be smooth.

### To Monitor the Sound While Viewing the Playback Picture in the Viewfinder

Connect headphones (not supplied) to the  jack. Play back the tape in VTR mode (p. 16).

## Connections for Playback

You can use this camcorder as a VCR by connecting it directly to your TV for playback. There are some ways to connect the camcorder to your TV. When monitoring the playback picture by connecting the camcorder to your TV, we recommend you to use house current for the power source (p. 18).

### Connecting to a TV with Video/Audio Input Jacks

Connect the camcorder to the inputs on the TV by using the supplied A/V connecting cable. Set the TV/VCR selector on the TV to VCR.

If you are going to connect the camcorder using the S video cable [a], you do not need to connect the yellow (video) plug of the A/V connecting cable [b].

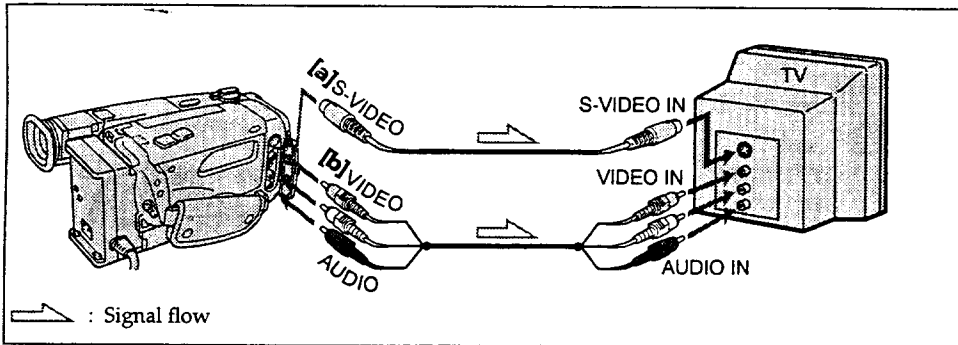

### If a VCR is already connected to your TV

Connect the camcorder to the LINE IN inputs on the VCR by using the A/V connecting cable. Set the input selector on the VCR to LINE. Set the TV/VCR selector on the TV to VCR.

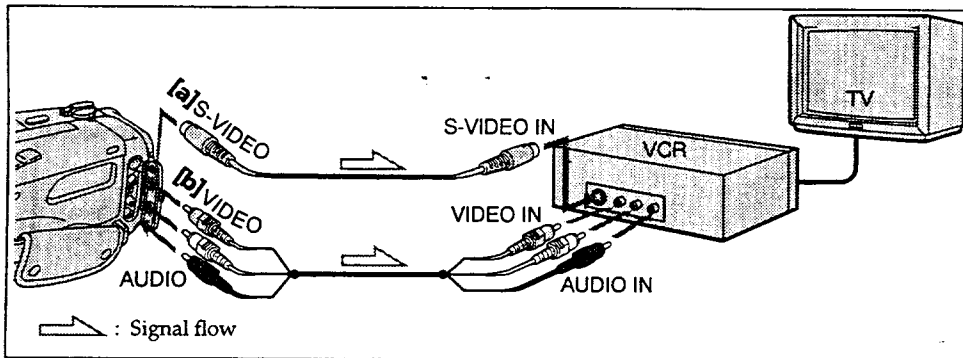

### If your TV or VCR is a monaural type

Connect only the white plug for audio on both the camcorder and the TV or the VCR. With this connection, the sound is monaural.

### To connect a TV or a VCR without Video/Audio input jacks

Use the RFU-95UC RFU adaptor (not supplied).

## Playing Back a Tape

You can monitor the playback picture in the viewfinder. You can also monitor the picture on a TV screen, after connecting the camcorder to a TV or VCR (p. 15). You can use the supplied Remote Commander to control playback.

- (1) While pressing the small green button on the POWER switch, turn it to VTR. The tape transport buttons light up.
- (2) Insert the recorded tape with the window facing out.
- (3) Press . Playback starts.

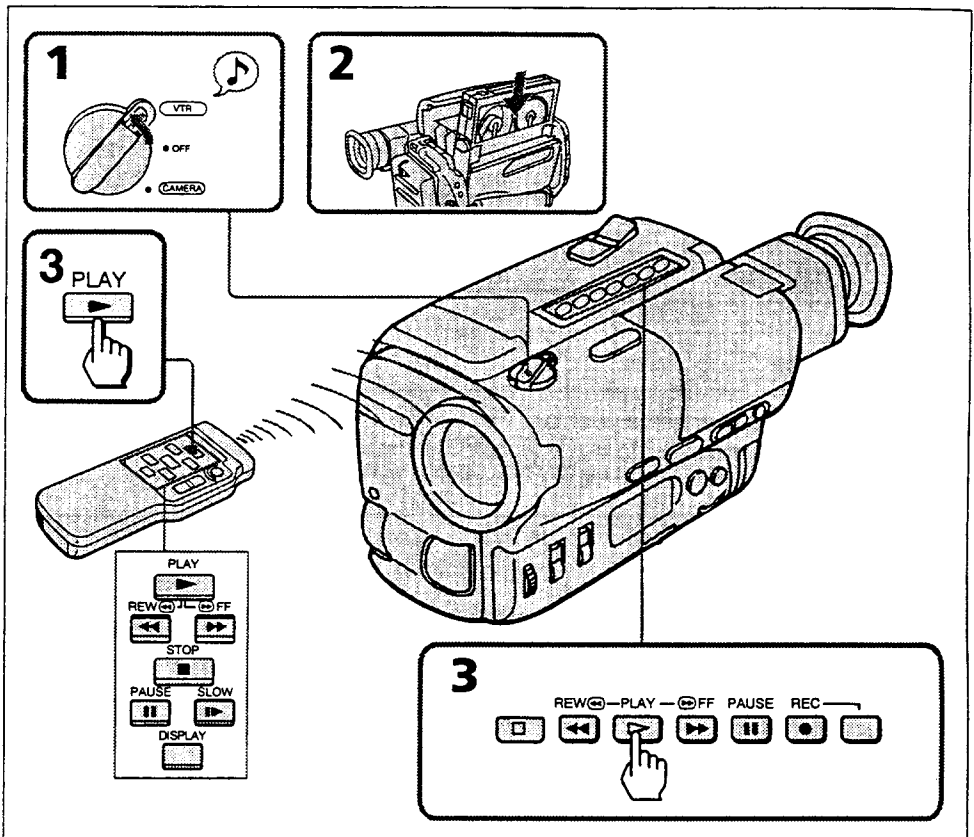

To stop playback, press .

To rewind the tape, press .

To advance the tape rapidly, press .





## Various Playback Modes

### To view a still picture (Playback pause)

Press **II** during playback. To resume playback, press **II** or **▷**.

### To locate a scene (Picture search)

Keep pressing **◀◀** or **▶▶** during playback. To resume normal playback, release the button.

### To monitor the high-speed picture while advancing the tape or rewinding (Skip scan)

Keep pressing **◀◀** while rewinding or **▶▶** while advancing the tape. To resume normal playback, press **▷**.

### To view the picture in a sequence of stop-motion images

Press **EDITSEARCH** in playback pause mode. If you keep pressing **EDITSEARCH**, you can view the picture play back in the forward (+) or reverse (-) direction.

### To view the picture at 1/5 speed (Slow playback) (only with the Remote Commander)

Press **▶** on the Remote Commander during playback. To resume normal playback, press **▶**. If slow playback lasts for about 1 minute, it shifts to normal speed automatically.

### Notes on playback

- Streaks appear and the sound is muted in the various playback modes.
- When playback pause mode lasts for 5 minutes, the camcorder automatically enters stop mode.

### To display the viewfinder screen indicators on the TV

Press **DISPLAY** on the Remote Commander. To erase the indicators, press **DISPLAY** again.

### To select the playback sound

Change the "HiFi SND" mode setting in the menu system (p. 31).

## Advanced Operations

# Using Alternative Power Sources

You can choose any of the following power sources for your camcorder: battery pack (p. 6), house current, and 12/24 V car battery. Choose the appropriate power source depending on where you want to use your camcorder.

Place	Power source	Accessory to be used
Indoors	House current	AC power adaptor AC-V25A/V25B/V25C/V15 (supplied), AC-S10
Outdoors	Battery pack	Battery pack NP-55 (supplied), NP-80/80D, NP-77H, NP-68, NP-66H, NP-C65, NP-60D
In the car	12 V or 24 V car battery	DC pack DCP-77

### Note on power sources

Disconnecting the power source or removing the battery pack during recording or playback may damage the inserted tape. If this happens, restore the power supply again immediately.

## Using House Current

— For the customers supplied with the AC-V25A/V25B/V25C AC power adapter

- (1) Lift up the viewfinder.
- (2) Connect the AC power cord to a wall outlet. Connect the bottom of the AC power adaptor to the battery mounting surface of the camcorder.
- (3) Set the selector to VTR (DC OUT).

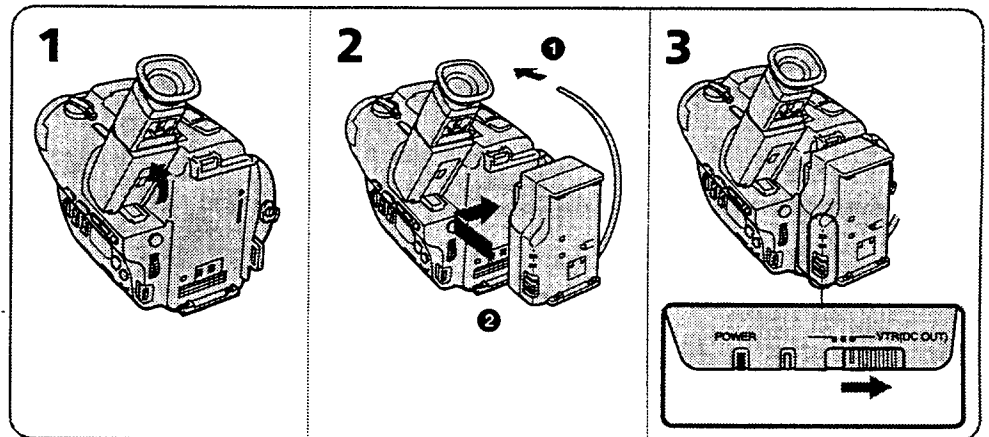

— For the customers supplied with the AC-V15 AC power adaptor

- (1) Lift up the viewfinder.
- (2) Connect the AC power cord to a wall outlet. Connect the connecting plate to the battery mounting surface of the camcorder.
- (3) Set the selector to VTR (DC OUT).

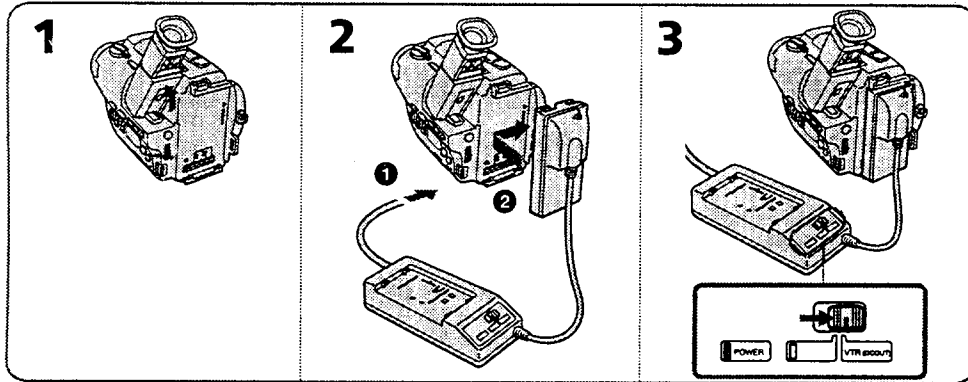

**WARNING**

The power cord must only be changed at qualified service shop.

**PRECAUTION**

The set is not disconnected from the AC power source (mains) as long as it is connected to the wall outlet, even if the set itself has been turned off.

**Notes on the POWER lamp**

- The POWER lamp will remain lit for a while even if the unit is unplugged after use. This is normal.
- If the POWER lamp does not light, set the selector to the center position (AC-V25A / V25B / V25C only) and disconnect the power cord. After about one minute, reconnect the power cord and set the selector to VTR (DC OUT) again.

**To remove the adaptor**

The adaptor is removed in the same way as the battery pack (p. 8).

## Using Alternative Power Sources

### Using a Car Battery

Use the DCP-77 DC pack (not supplied). Connect the cord of the DC pack to the cigarette lighter socket of the car (12 V or 24 V). Connect the DC pack to the battery mounting surface of the camcorder.

#### To remove the DC pack

The DC pack is removed in the same way as the battery pack (p. 8).

### Options for Charging the Battery Pack

- AC-S10 AC power adaptor:  
You can charge a battery pack whether it is used up or not with this adaptor because it has a discharging function.
- BC-S10 portable battery charger (ideal for travel):  
You can charge a battery pack on 100 – 240 V AC current.



This mark indicates that this product is a genuine product related to our 8 mm video equipment.

We recommend that you purchase related 8 mm video products provided with the same mark or products provided with our logotype mark.

## Recording with the Date or Time

Before you start recording, press DATE or TIME. You can record the date or time displayed in the viewfinder with the picture. You cannot record the date and time at the same time. Except for the date or time indicator, no indicator in the viewfinder is recorded.

The clock is set to the East Coast Standard Time at the factory, but you can reset the clock in the menu system (p. 35).

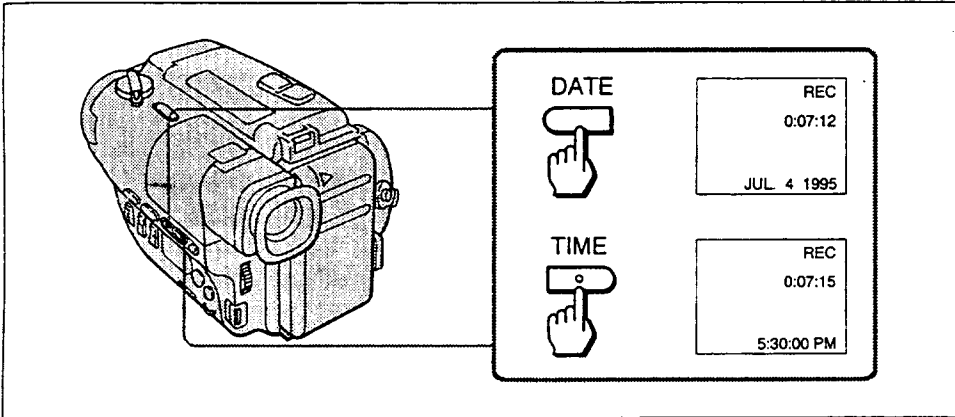

### To Stop Recording with the Date or Time

Press DATE or TIME again. The date or time indicator disappears. The recording continues.

## Using the PROGRAM AE Function

You can select from four PROGRAM AE (Auto Exposure) modes to suit your shooting situation. When you use PROGRAM AE, you can get a Portrait effect (the subject is in focus and the background is out of focus), capture high-speed action, or record night views.

### Selecting the Best Mode

Select one of four modes, referring to the following.

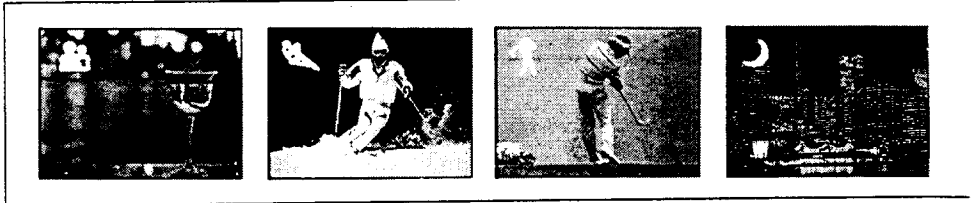

#### Portrait mode

- A still subject such as a person or a flower
- Zooming in on a subject in the telephoto mode
- A subject behind an obstacle such as a net

#### Sports mode

- Outdoor sports scenes such as football, tennis, golf or skiing
- A landscape from a moving car

#### High-speed shutter mode

- A golf swing or a tennis match in fine weather with the ball captured clearly
- Playing back certain scenes with high-speed movements in a clear, sharp picture

#### Twilight mode

- Recording night views, neon signs or fireworks

### Using the PROGRAM AE Function

Press PROGRAM AE. The indicator of the selected PROGRAM AE mode appears in the viewfinder.

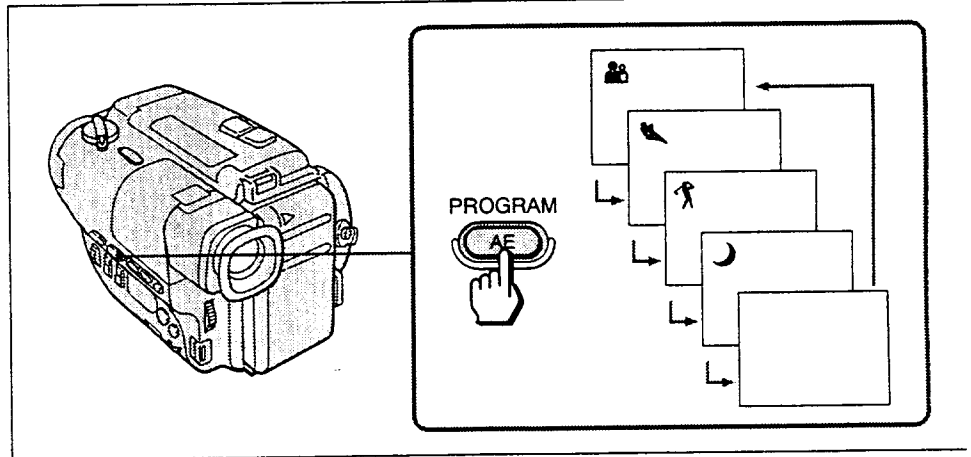

#### Note on shutter speed

The shutter speed in each PROGRAM AE mode is as follows:

Portrait mode — between 1/60 to 1/2000

Twilight mode — 1/60

Sports mode — between 1/60 to 1/500

Normal mode — 1/60

High-speed shutter mode — 1/4000

# Fade-in and Fade-out

You can fade in or out to give your recording a professional appearance.

When fading in, the picture gradually fades in from black or mosaic while the sound increases. When fading out, the picture gradually fades to black or mosaic while the sound decreases.

## When Fading in [a]

- (1) While the camcorder is in Standby mode, press FADER. The fade indicator starts flashing.
- (2) Press START/STOP to start recording. The fade indicator stops flashing.

## When Fading out [b]

- (1) During recording, press FADER. The fade indicator starts flashing.
- (2) Press START/STOP to stop recording. The fade indicator stops flashing, and then recording stops.

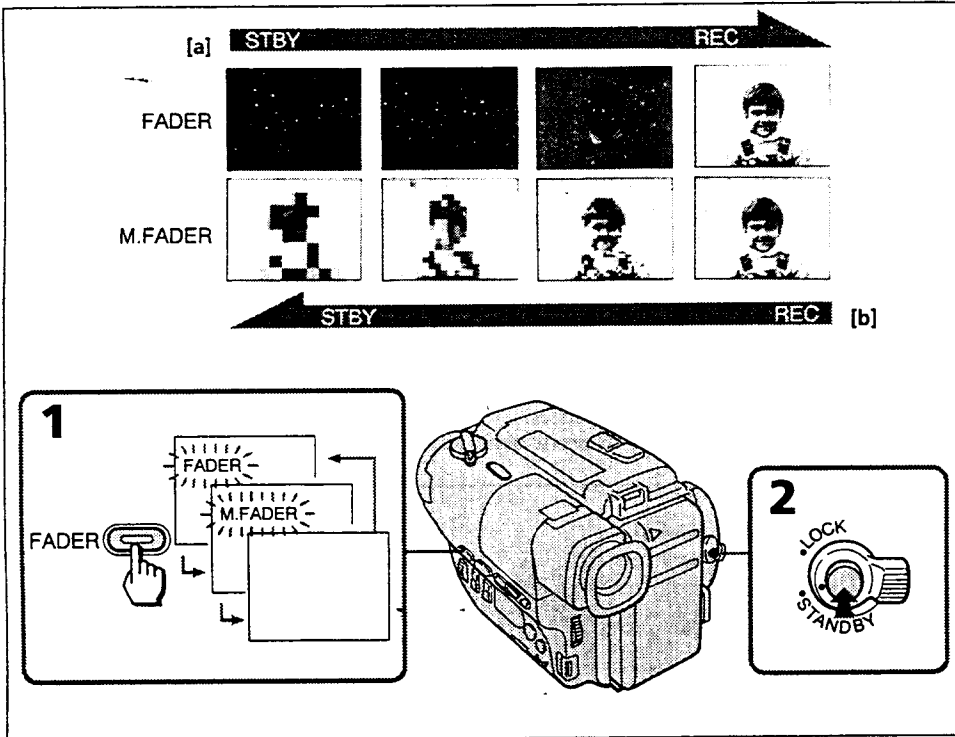

## To Cancel the Fade-in/Fade-out Function

Before pressing START/STOP, press FADER until the fade indicator disappears.

## When the date or time indicator is displayed

The date or time indicator does not fade in nor fade out.

# Focusing Manually

## When to Use Manual Focus

In the following cases you should obtain better results by adjusting the focus manually.

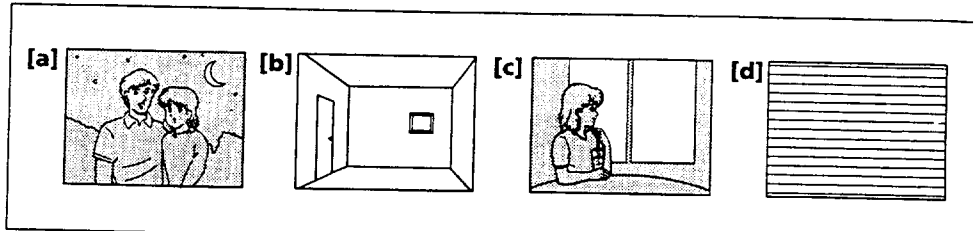

- Insufficient light [a]
- Subjects with little contrast — walls, sky, etc. [b]
- Too much brightness behind the subject [c]
- Horizontal stripes [d]
- Subjects through frosted glass
- Subjects beyond nets, etc.
- Bright subject or subject reflecting light
- Shooting a stationary subject when using a tripod

## Focusing Manually

When focusing manually, first focus in telephoto before recording, and then reset the shot length.

- (1) Set FOCUS to MANUAL. The indicator appears in the viewfinder.
- (2) Keep pressing the "T" (telephoto) side of the power zoom button until the zooming stops.
- (3) Turn the focus dial to achieve a sharp focus.
- (4) Set the desired shot length using the power zoom button.

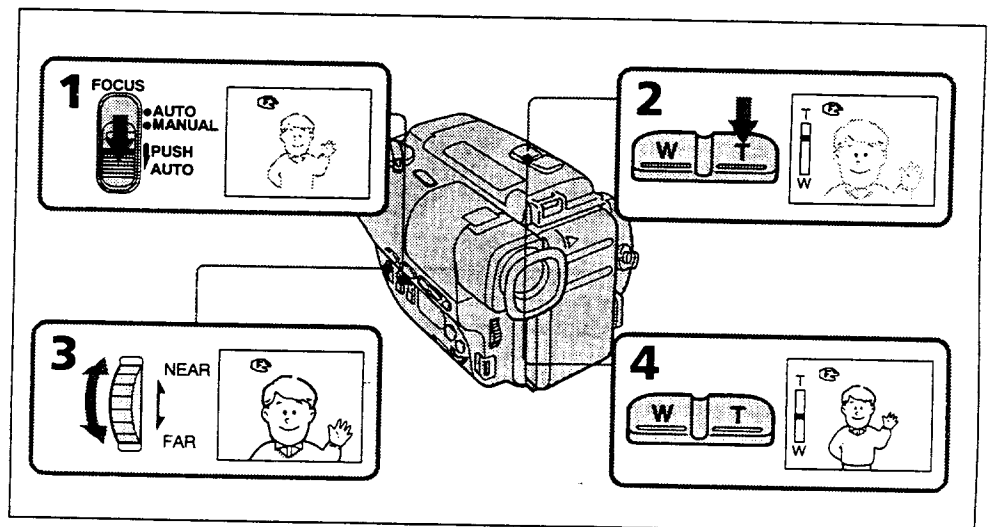



### To Return to Autofocus Mode

Set FOCUS to AUTO. The  indicator in the viewfinder disappears.

### Shooting in relatively dark places

Shoot at wide-angle after focusing in the telephoto position.

### Note on the focus dial

The focus dial does not have a stop position.

### To Shoot with Autofocus Momentarily

When you want to switch to autofocus momentarily while recording in manual focus mode, push FOCUS down to PUSH AUTO. Autofocus functions while FOCUS is held down. When it is released, manual focus mode will be resumed.

## Releasing the STEADY SHOT Function

### – For the Model with the STEADY SHOT Switch (CCD-TR600 only)

When you shoot, the  indicator appears in the viewfinder. This indicates that the Steady shot function is working and the camcorder compensates for camera-shake.

You can release the Steady shot function when you do not need to use the Steady shot function. Do not use the Steady shot function when shooting a stationary object with a tripod.

Set STEADY SHOT to OFF.

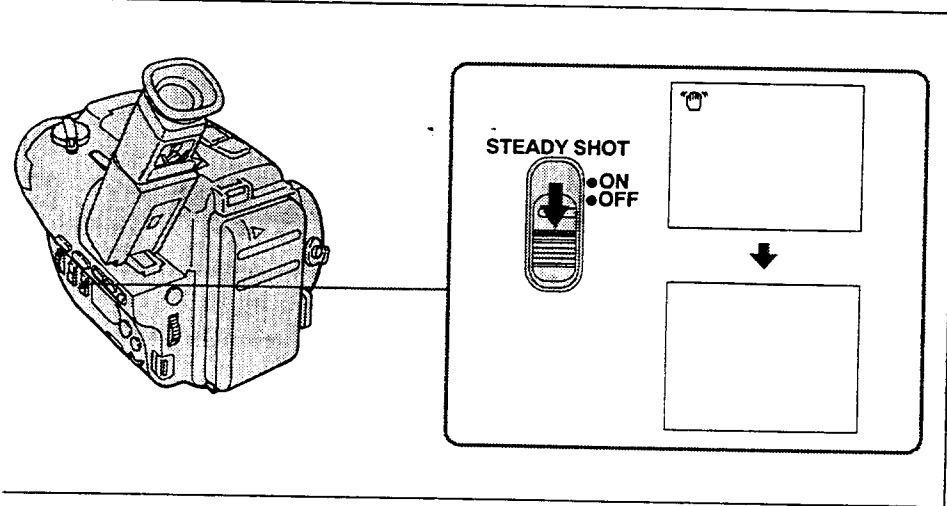

### to Activate the Steady Shot Function Again

Set STEADY SHOT to ON.

### Notes on the Steady shot function

The Steady shot function will not correct excessive camera-shake.

When you switch the STEADY SHOT function on or off, the exposure may fluctuate.

## Enjoying Picture Effect

### Selecting Picture Effect

You can make pictures like those of television with Picture Effect function.

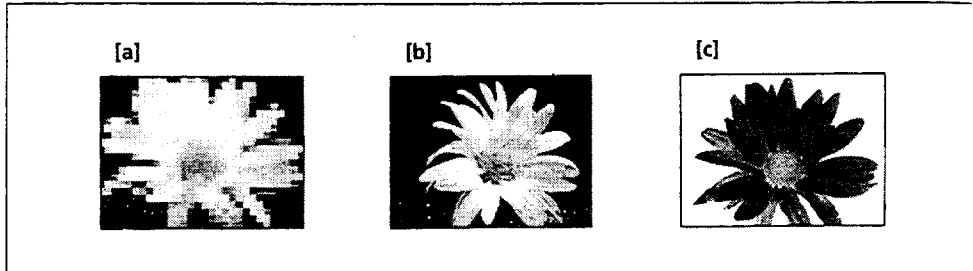

**MOSAIC [a]**

The picture is mosaic.

**SOLARIZE [b]**

The light intensity is more clear, and the picture looks like an illustration.

**B&W**

The picture is monochrome (black and white).

**SEPIA**

The picture is sepia.

**NEG. ART [c]**

The color of the picture is reversed.

### Picture Effect Modes for CCD-TR600 only

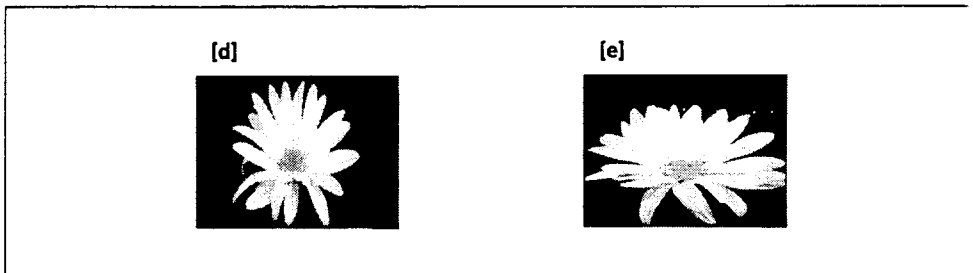

**SLIM [d]**

The picture expands vertically.

**STRETCH [e]**

The picture expands horizontally.

## Using Picture Effect Function

Press PICTURE EFFECT to select the desired Picture Effect mode.

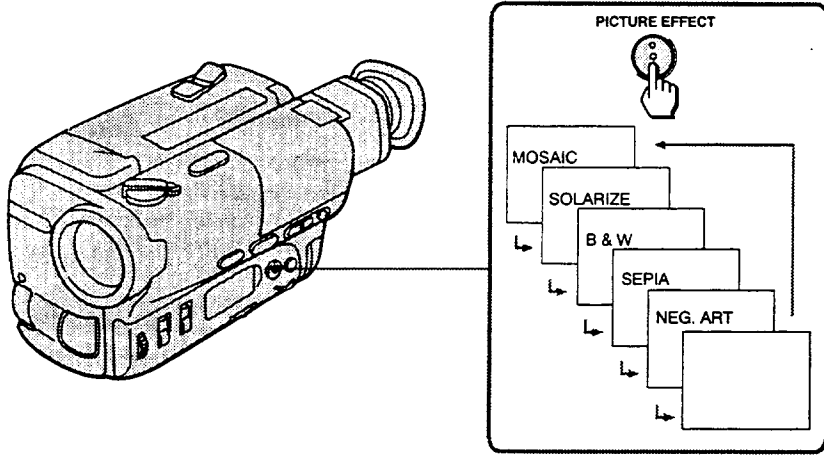

### Note on Picture Effect

When you turn the power off, the camcorder returns automatically to normal mode.

# Adjusting the Exposure

## When to Adjust the Exposure

Adjust the exposure manually under the following cases.

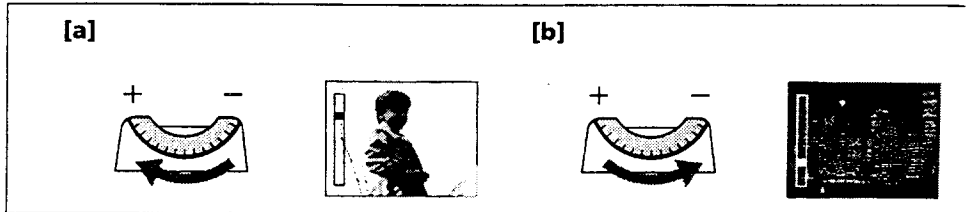

**[a]** Turn the exposure dial to + when:

- The background is too bright (back lighting)
- Insufficient light: most of the picture is dark

**[b]** Turn the exposure dial to - when:

- Bright subject and dark background
- To record the darkness faithfully

## Adjusting the Exposure

- (1) Press EXPOSURE. The exposure indicator appears in the viewfinder. The exposure is locked at the actual brightness.
- (2) Turn the exposure dial to adjust the exposure. The exposure is locked at the adjusted brightness.

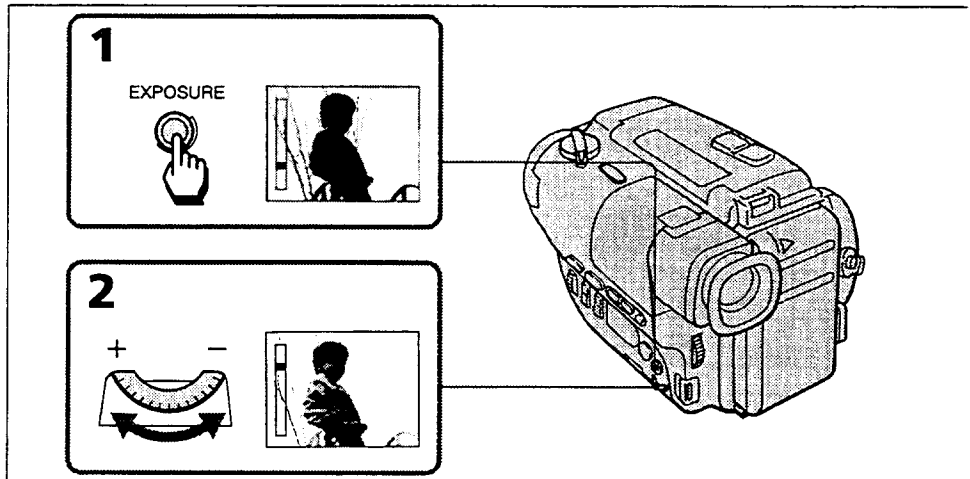

### To Return to Automatic Exposure Mode

Press EXPOSURE again.

### Shooting with the sun behind you

If the light source is behind your subject, or in the following situations, the subject will be recorded too dark.

- The subject is indoors and there is a window behind the subject.
- Bright light sources are included in the scene.
- When shooting a person wearing white or shiny clothes in front of a white background, the face will be recorded too dark.

### Shooting in the dark

**28** We recommend you to use a video light (not supplied). To get the best color, you must maintain a sufficient light level.

## Shooting Scenery in Several Short Takes

Long, continuous shots of scenery tend to be dull, and have to be edited to make an interesting video. With the 5SEC. REC (5-second recording) mode, the camcorder records for only 5 seconds and then switches to Standby mode, so that you will automatically take a series of quick shots resulting in a lively video.

(1) Set REC TIME to 5 SEC.

(2) Turn STANDBY up and press START/STOP. Recording starts. "5SEC. REC" indicator appears in the viewfinder and changes to five dots.

The dots disappear at a rate of one per second. When five seconds elapse and all the dots disappear, the camcorder switches to Standby mode automatically.

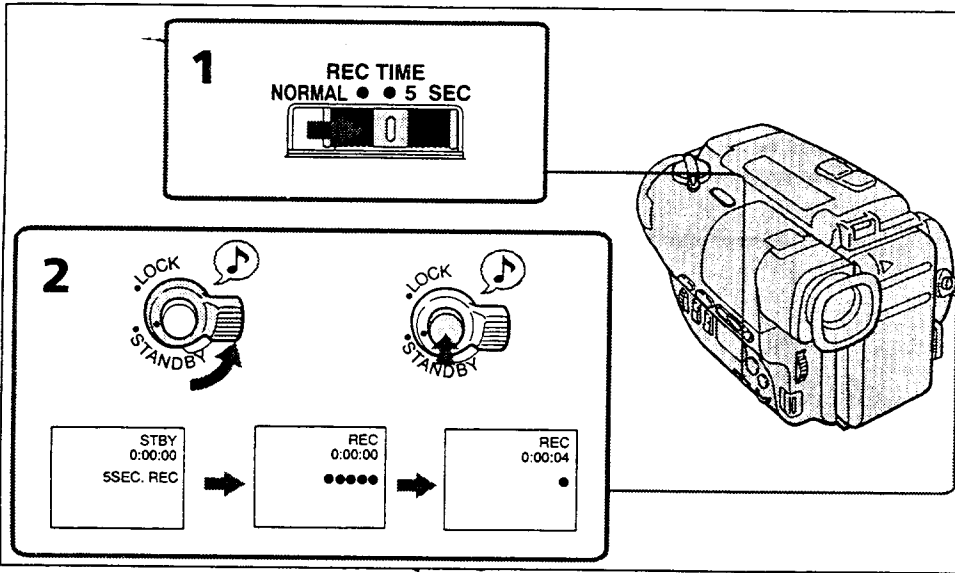

### To Extend the Recording Time

Press START/STOP again before all the dots disappear. Recording continues for 5 seconds from the moment you press START/STOP.

### To Cancel 5-Second Recording

Set REC TIME to NORMAL. If you set the switch while recording, recording continues.

### Note on 5-second recording

You cannot use FADER function during 5-second recording.

# Changing the Mode Settings

You can change the mode settings in the menu system to further enjoy the features and functions of the camcorder.

- (1) Press MENU to display the menu in the viewfinder.
- (2) Turn the menu dial to select the desired item, then press the dial.
- (3) Turn the menu dial to set the desired mode, then press the dial. If you want to change the other modes, repeat steps 2 and 3.
- (4) Press MENU to erase the menu display.

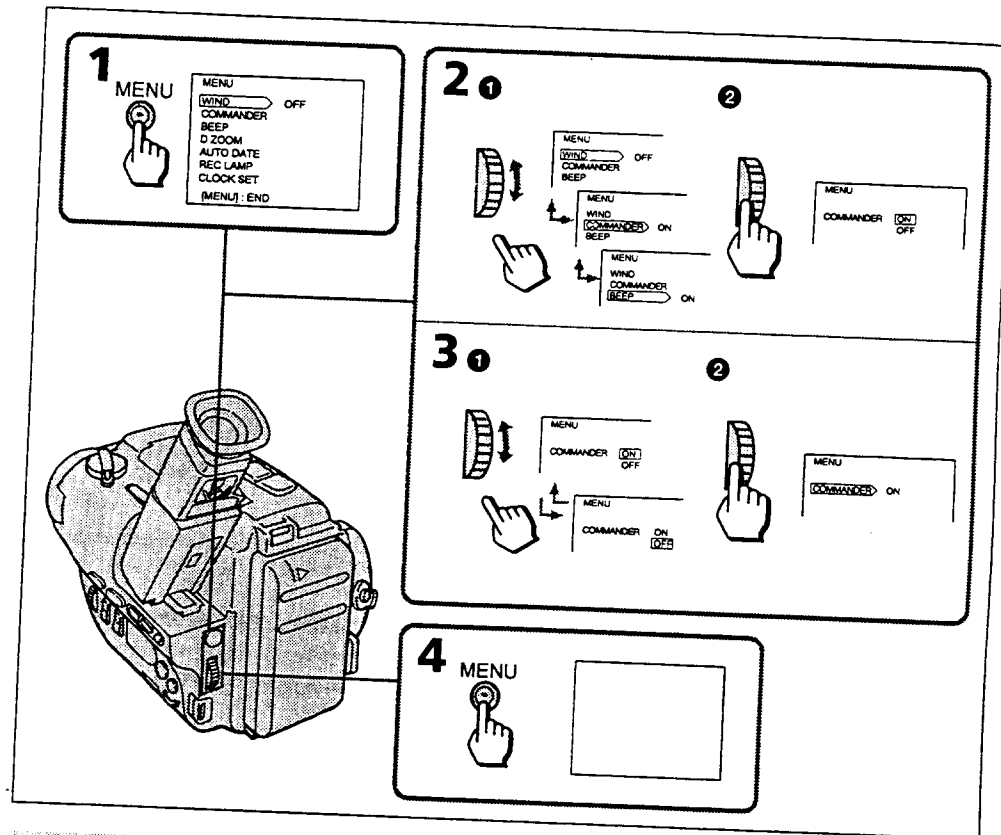

## Selecting the Mode Setting of Each Item

### Items for both CAMERA and VTR Modes

#### COMMANDER <ON/OFF>

- Select ON when using the supplied Remote Commander for the camcorder.
- Select OFF when not using the Remote Commander.

#### BEEP <ON/OFF>

- Select ON so that beeps sound when you start/stop recording, etc.
- Select OFF when you do not want to hear the beep sound.



### **CLOCK SET\***

Select this item to reset the date or time.

### **Items for CAMERA Mode Only**

#### **WIND <ON/OFF>**

- Select ON to reduce wind noise when recording in strong wind.
- Normally select OFF.

#### **D ZOOM <ON/OFF>\* (CCD-TR600 only)**

- Select ON to activate digital zooming.
- Select OFF to not use the digital zoom. The camcorder goes back to 12x zoom.

#### **AUTO DATE\* <ON/OFF>**

- Select ON to record the date for 10 seconds after recording has started.
- Select OFF to not record the date.

#### **REC LAMP\* <ON/OFF>**

- Select OFF when you do not want the camera recording/battery lamp at the front of the unit to light up.
- Normally select ON.

### **Items for VTR Mode Only**

#### **EDIT <ON/OFF>**

- Select ON to minimize picture deterioration when editing.
- Normally select OFF.

#### **iFi SND <STEREO/1/2>**

- Normally select STEREO.
- Select 1 or 2 to play back a dual sound track tape.

These settings are retained even when the battery is removed, as long as the lithium battery is in place.

## Editing onto Another Tape

You can create your own video program by editing with any other **8** mm, **Hi8**, **Hi8**, **VHS**, **S-VHS**, **S-VHS**, **S-VHS**, **S-VHS**, **B** Betamax or **ED** Betamax VCR that has audio/video inputs.

### Before Editing

Connect the camcorder to the VCR using the supplied A/V connecting cable (p. 15). Set the input selector on the VCR to LINE, if available.

- (1) While pressing the small green button on the POWER switch, turn it to VTR.
- (2) Set EDIT to ON in the menu system.

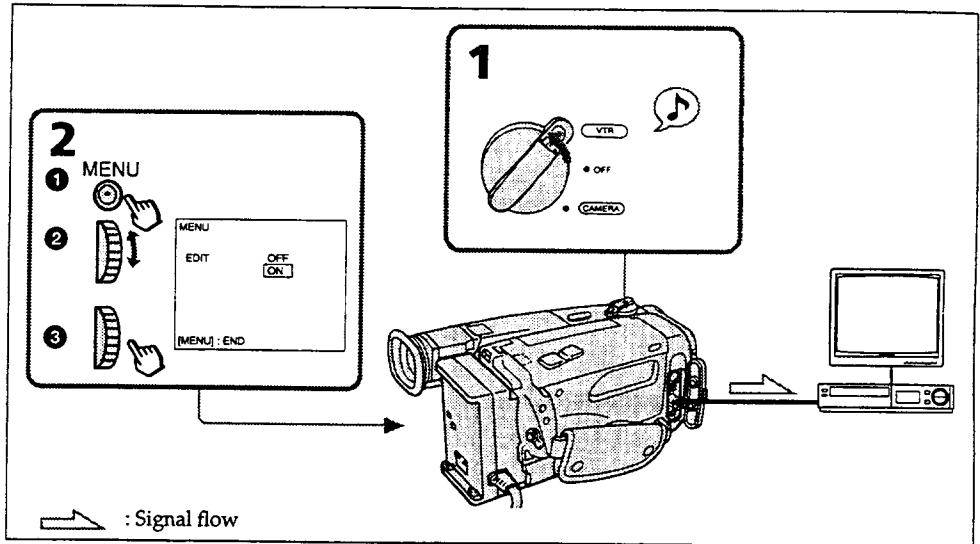

### Starting Editing

- (1) Insert a blank tape (or a tape you want to record over) into the VCR, and insert your recorded tape into the camcorder.
- (2) Play back the recorded tape on the camcorder until you locate the point where you want to start editing, then set the camcorder in playback pause mode.
- (3) On the VCR, locate the recording start point and set the VCR in the recording pause mode.
- (4) Press **II** on the camcorder and VCR simultaneously to start editing.

#### To Edit More Scenes

Repeat steps 2 to 4.

#### To Stop Editing

Press **□** on both the camcorder and the VCR.

#### Use of the EDITSEARCH button

You can play back the tape in normal/reverse direction by holding down EDITSEARCH during playback pause mode. You can also play back still pictures successively at specific intervals by pressing EDITSEARCH intermittently.

#### Note on the DISPLAY function

- 32** If you have displayed the viewfinder screen indicators on the TV, erase the indicators by pressing DISPLAY on the Remote Commander so that they will not be superimposed on the edited tape.



## Recording from a VCR or TV

You can record a tape from another VCR or a TV program from a TV that has video/audio outputs. Connect the camcorder to the TV or VCR.

- (1) While pressing the small green button on the POWER switch, turn it to VTR.
  - (2) Press REC ● and the button on the right together at the point where you want to start recording.
- In recording and recording pause mode, S VIDEO and VIDEO/AUDIO jacks automatically work as input jacks.

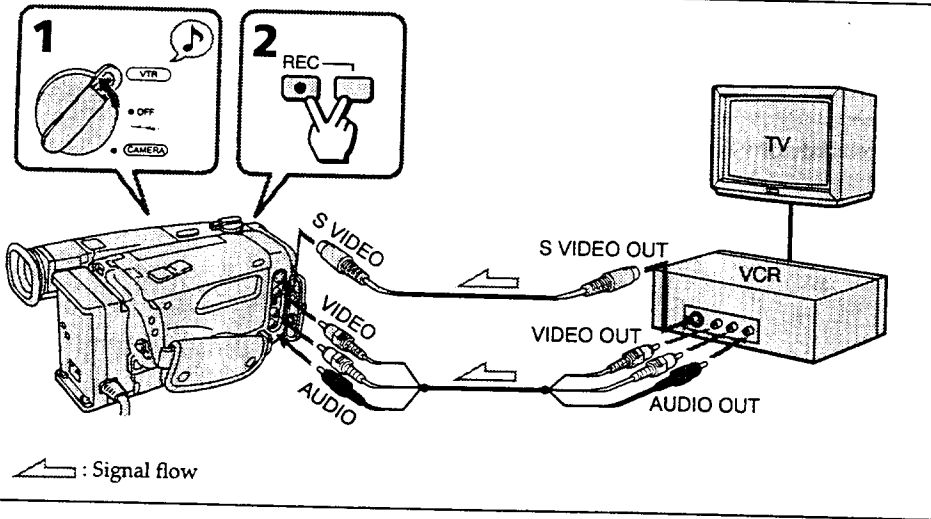

If your TV or VCR is a monaural type, connect only the white plug for audio on both the camcorder and the TV or VCR.

If you are going to connect the camcorder using the S video cable, you do not need to connect the yellow (video) plug of the A/V connecting cable.

o **Check the Picture from a TV or VCR before Recording**  
Press **II** after pressing **●**. You can check the picture in the viewfinder.

o **Stop Recording**  
Press **□**.

## Additional Information

# Changing the Lithium Battery

Your camcorder is supplied with a lithium battery installed. The lithium battery for the camcorder lasts for about 1 year under normal operation. When the battery becomes weak or dead, the  $\mathcal{S}$  indicator flashes in the viewfinder for about 5 seconds when you set the POWER switch to CAMERA. In this case, replace the battery with a Sony CR2025 or Duracell DL-2025 lithium battery. Use of another battery may present a risk of fire or explosion.

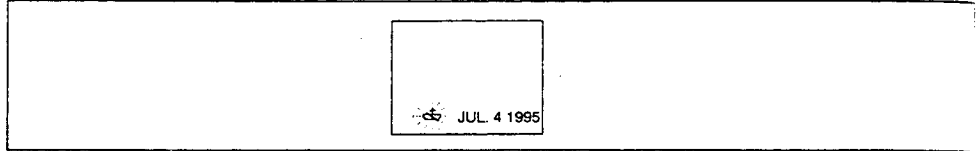

### Note on Lithium Battery

The lithium battery has a positive (+) side and a negative (-) side as illustrated. Be sure to insert the lithium battery with the positive side facing out.

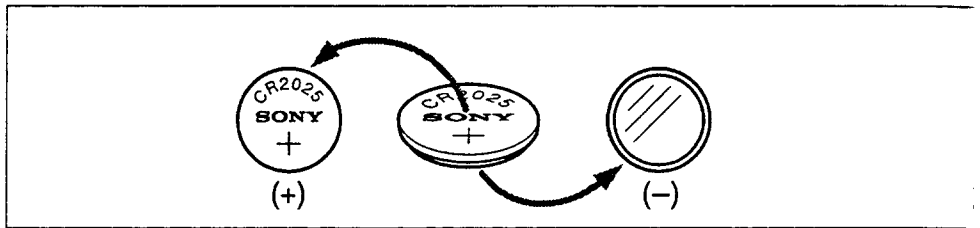

### WARNING

Battery may explode if mistreated. Do not recharge, disassemble, or dispose of in fire.

### Caution

Keep the lithium battery out of the reach of children. Should the battery be swallowed, consult a doctor immediately.

## Changing the Lithium Battery

When replacing the lithium battery, keep the battery pack or other power source attached. Otherwise, you will need to reset the date, time and other items in the menu system retained by the lithium battery.

- (1) Open the lid of lithium battery compartment under the grip strap of the camcorder.
- (2) Push the battery down once and pull it out from the holder.
- (3) Install the lithium battery with the positive (+) side facing out. Close the lid.

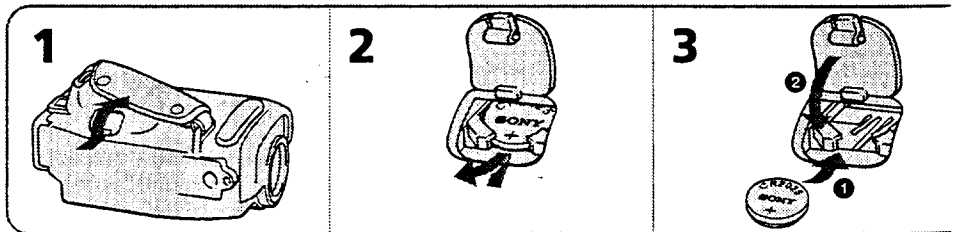

# Resetting the Date or Time

You can reset the date or time in the menu system.

- (1) Press MENU to display the menu in the viewfinder.
- (2) Select CLOCK SET, then press the menu dial.
- (3) Turn the menu dial to adjust the year, and then press the dial.
- (4) Set the month, day, hour and minutes by turning the menu dial and pressing it.
- (5) Press MENU to erase the menu display.

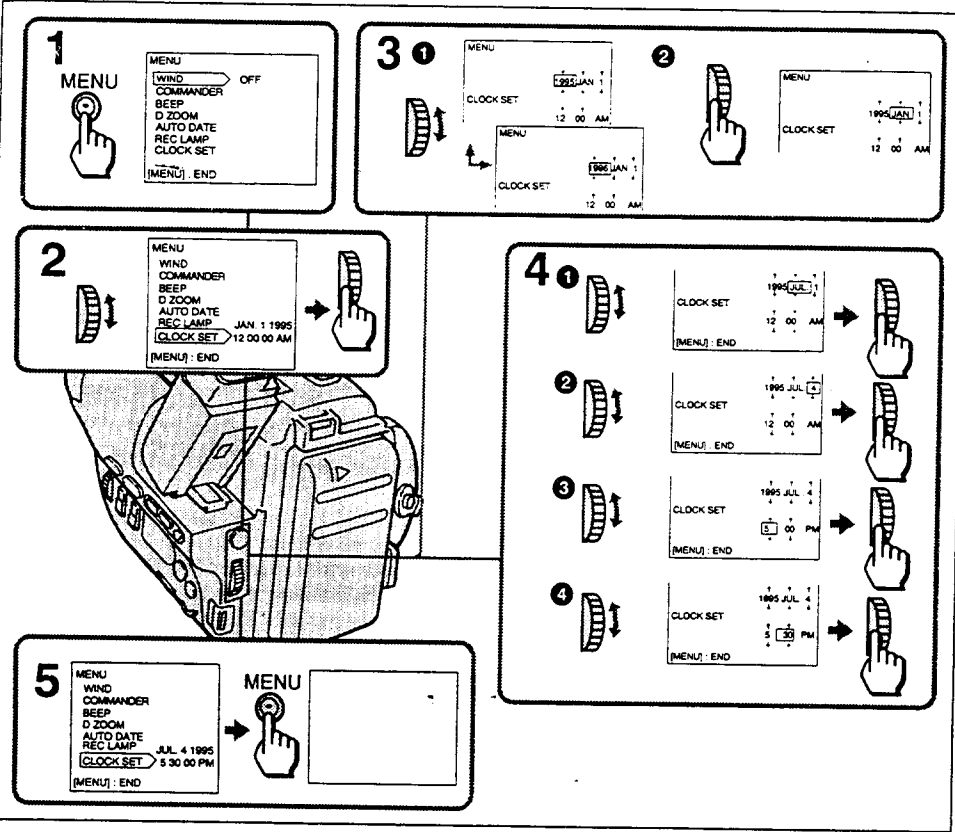

Additional Information

**o Correct the Date and Time Setting**  
Repeat steps 2 to 4.

**o Check the Preset Date and Time**  
Press DATE to display the date indicator in the viewfinder.  
Press TIME to display the time indicator. When you press the same button again, the indicator goes off.

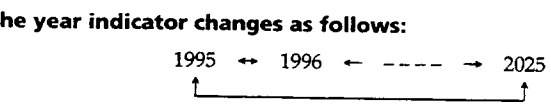

**Note on the time indicator**  
The internal clock of this camcorder operates on a 12-hour cycle.  
12:00 AM stands for midnight.  
12:00 PM stands for noon.

## Playback Modes

### Selecting Cassette Types

This Hi8 system is an extension of the standard 8 mm system, and was developed for higher-quality pictures.

You can use Hi8 video and standard 8 mm cassettes. When you use a Hi8 video cassette, the recording is in the Hi8 system. When you use a standard 8 mm cassette, the recording is in the standard 8 mm system. You cannot record on standard 8 mm cassettes in the Hi8 system.

If you are going to play back the tape using a standard 8 mm video recorder/player, you should use standard 8 mm cassettes.

### When You Play Back

The playback mode (SP/LP or Hi8/standard 8 mm) is selected automatically according to the format in which the tape has been recorded. The quality of the recorded picture in LP mode, however, will not be as good as that in SP mode.

#### Note on AFM Hi-Fi stereo

When you play back a tape, the sound will be in monaural if:

- You record the tape using this camcorder, then play it back on an AFM Hi-Fi monaural video recorder/player.
- You record the tape on an AFM Hi-Fi monaural video recorder, then play it back on this camcorder.

#### LP (long play) mode

When you play back a tape recorded in LP mode, the LP indicator lights up in the viewfinder. This camcorder cannot record a tape in LP mode.

#### Foreign 8 mm video

You cannot play back software recorded on a different TV color system. Because the TV color systems differ from country to country, you may not be able to play back foreign pre-recorded software. Refer to page 42 to check the TV color system of foreign countries.

## Tips for Using the Battery Pack

This section shows you how you can get the most out of your battery pack.

### Preparing the Battery Pack

#### Always Carry Additional Batteries

Have sufficient battery pack power to do 2 to 3 times as much recording as you have planned.

#### Battery Life is Shorter in Cold Environment

Battery efficiency is decreased and the battery will be used up more quickly if you are recording in a cold environment.

#### To Save Battery Power

Turn STANDBY on the camcorder down when not recording to save battery power [a].

A smooth transition between scenes can be made even if recording is stopped and started again. While you are positioning the subject, selecting an angle, or looking through the viewfinder lens, the lens moves automatically and the battery is used. The battery is also used when a tape is inserted or removed.

## Tips for Using the Battery Pack

### When to Replace the Battery Pack

While you are using your camcorder, the remaining battery indicator in the viewfinder decreases gradually as battery power is used up.



When the remaining battery indicator reaches the lowest point, the  indicator appears and starts flashing in the viewfinder [b].

When the  indicator in the viewfinder changes from slow flashing to rapid flashing while you are recording, turn the POWER switch to OFF on the camcorder and replace the battery pack. Leave the tape in the camcorder to obtain a smooth transition between scenes after the battery pack is replaced.

### Note on the remaining battery indicator

The remaining battery indicator of the camcorder may indicate a different remaining capacity from that of the battery pack with its own indicator (not supplied). The indicator on the battery pack is more accurate.

### Notes on the Rechargeable Battery Pack

#### The Battery Pack Heats Up

During charging or recording, the battery pack heats up. This is caused by energy that has been generated and a chemical change that has occurred inside the battery pack. This is not cause for concern.

#### Battery Pack Care

- Remove the battery pack from the camcorder after using the battery pack, and keep it in a cool place.
- When the battery pack is attached to the camcorder, a small amount of current flows to the camcorder even if the POWER switch is set to OFF, which shortens battery life.
- The battery pack is always discharging even when it is not in use after charging. Therefore, you should charge the battery pack right before using the camcorder.

#### How to Use the Switch on the Battery Pack

When the switch is supplied with the battery pack [c], you can use it to find whether the battery pack is charged or not. Set the switch to the "no mark" position when charging is completed. Set the switch to the "red mark" position when the battery is used up (or in whichever direction you want to remind yourself).

#### The Life of the Battery Pack

If the battery indicator flashes rapidly just after turning on the camcorder with a fully charged battery pack, the battery pack should be replaced with a new fully charged one.

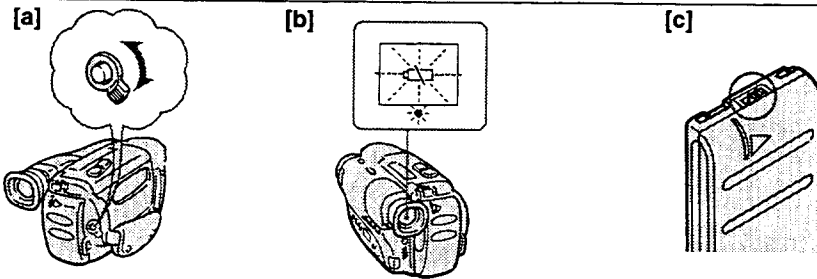

Additional Information

## Tips for Using the Battery Pack

### Charging Temperature

You should charge batteries at temperatures from 50 °F to 86 °F (from 10 °C to 30 °C). Lower temperatures require a longer charging time.

### Sony Batteries are Recommended

Use of non-Sony batteries may damage your Handycam camcorder.

## Notes on Charging

### A Brand-new Battery Pack

A brand-new battery pack is not charged. Before using the battery pack, charge it completely.

### Before Recharging a Used Battery Pack

- Make sure to use up the battery before recharging.
- If recording is completed before the  indicator appears in the viewfinder, you should remove the tape, turn the POWER switch to CAMERA, turn STANDBY up, and leave the camcorder until the battery indicator flashes rapidly.
- When you use the AC-S10 power adaptor or the BC-S10 portable battery charger, you can use the discharging function.
- **Charging a usable battery pack causes a lowering of battery capacity. Battery capacity can be recovered if you fully discharge and charge the battery pack again.**

### After Long Storage

Recharge the battery pack after a long period of storage. If the battery pack is charged fully but not used for a long time (about 1 year), it becomes discharged. Charge it again, but in this case the battery life will be shorter than normal. After several charging and discharging cycles, the battery life will recover its original capacity.

## Notes on the Terminals

If the terminals (metal parts on the back) are not clean, the battery duration will be shortened. When the terminals are not clean or when the battery pack has not been used for a long time, repeatedly install and remove the battery pack. This improves the contact condition. Also, wipe the + and - terminals with a soft cloth or paper.

### Be Sure to Observe the Following

- **To prevent an accident caused by a short circuit, do not allow metal objects such as a necklace to touch the battery terminals. When carrying the battery pack, attach the terminal cover [d].**
- Keep the battery pack away from fire.
- Keep the battery pack dry.
- Do not open nor convert the battery pack.
- Do not expose the battery pack to any mechanical shock.

[d]

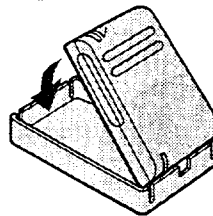



# Maintenance Information and Precautions

## Moisture Condensation

If the camcorder is brought directly from a cold place to a warm place, moisture may condense inside the camcorder, on the surface of the tape, or on the lens. In this condition, the tape may stick to the head drum and be damaged or the unit may not operate correctly. To prevent possible damage under these circumstances, the camcorder is furnished with moisture sensors. However, take the following precautions.

### Inside the Camcorder

When the  and  indicators flash in the viewfinder, moisture has condensed inside the camcorder. If this happens, no other functions except for tape ejection will work.

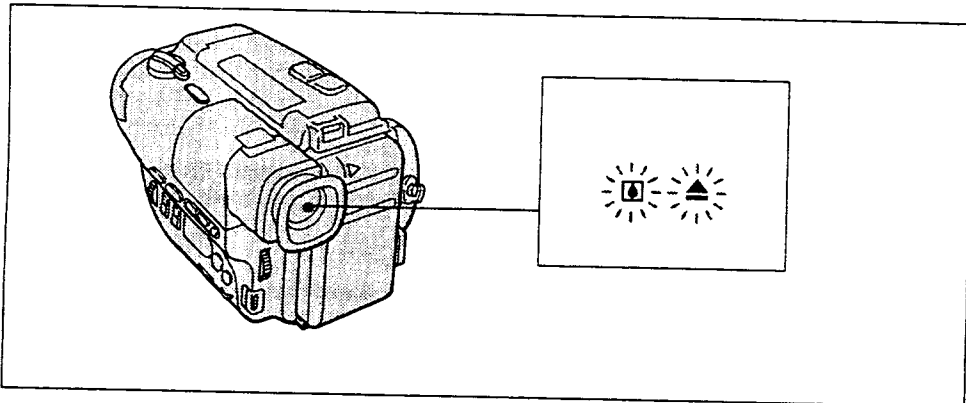

**Eject the tape, turn off the camcorder and leave it with the cassette holder open for at least one hour.** The camcorder can be used again if the  indicator does not appear when the power is turned on again.



Additional Information



### On the Surface of the Tape

If there is moisture on the surface of the tape, when you insert the cassette and press a tape transport button ( PLAY, etc.), the  indicator in the viewfinder flashes.

In this case, no other functions except for tape ejection will work.

**Eject the tape, turn off the camcorder and leave it with the cassette holder open for at least one hour.** The camcorder can be used again if the  indicator does not appear when you insert the cassette and press one of the tape transport buttons.

### On the Lens

If moisture condenses on the lens, no indicator appears, but the picture becomes dim. Turn off the power and do not use the camcorder for about one hour.



### How to Prevent Moisture Condensation

When bringing the camcorder from a cold place to a warm place, put the camcorder in a plastic bag and allow it to adapt to room conditions over a period of time.

- 1) Be sure to tightly seal the plastic bag containing the camcorder.
- 2) Remove the bag when the air temperature inside it has reached the temperature surrounding it (after about 1 hour).

## Maintenance Information and Precautions

### Video Head Cleaning

To ensure normal recording and clear pictures, clean the video heads. When the  indicator and "  CLEANING CASSETTE" message appear one after another in the viewfinder or playback pictures are "noisy" or hardly visible, the video heads may be dirty.



[a] Slightly dirty  
[b] Very dirty

If this happens, clean the video heads with the Sony V8-25CLH cleaning cassette (not supplied). After checking the picture, if it is still "noisy," repeat the cleaning. (Do not repeat cleaning more than 5 times.)

#### Caution

Do not use a commercially available wet-type cleaning cassette. It may damage the video heads.

#### Note

If the V8-25CLH cleaning cassette is not available in your area, consult your nearest Sony dealer.

### Removing Dust from Inside the Viewfinder

#### — For the Model with a Monochrome Viewfinder (CCD-TR100 only)

- (1) While holding down the switch on the viewfinder barrel, slide the eyecup to the left.
- (2) Clean the surface with a commercially available blower.

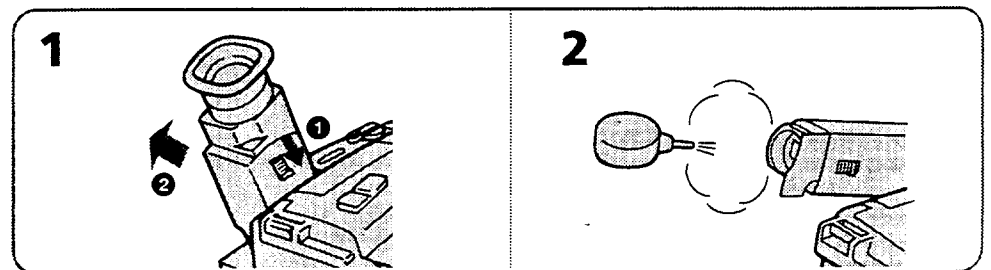



## Precautions

### Camcorder Operation

- Operate the camcorder on 6.0 V (battery pack) or 7.5 V (AC power adaptor).
- For DC or AC operation, use the accessories recommended in this manual.
- Should any solid object or liquid get inside the casing, unplug the camcorder and have it checked by Sony dealer before operating it any further.
- Avoid rough handling or mechanical shock. Be particularly careful of the lens.
- Keep the POWER switch set to OFF when not using the camcorder.
- Do not wrap up the camcorder and operate it since heat may build up internally.
- Keep the camcorder away from strong magnetic fields or mechanical vibration.

### On Handling Tapes

Do not insert anything in the small holes on the rear of the cassette. These holes are used to sense the type, thickness of tape, if the tab is out or in, etc.

### Camcorder Care

- When the camcorder is not to be used for a long time, disconnect the power source and remove the tape. Periodically turn on the power, operate the camera and player sections and play back a tape for about 3 minutes.
- Clean the lens with a soft brush to remove dust. If there are fingerprints on it, remove them with a soft cloth.
- Clean the camcorder body with a dry soft cloth, or a soft cloth lightly moistened with a mild detergent solution. Do not use any type of solvent which may damage the finish.

### AC Power Adaptor

#### Charging

- Repeated charging while some capacity remains causes a lowering of battery capacity. However, the original battery capacity can be recovered if you use the battery completely and charge it fully again.
- Charge the battery pack on a flat surface without vibration.
- The battery pack will get hot during charging. This is normal.

#### Others

- Model for the USA and Canada: One blade of the plug is wider than the other for the purpose of safety and will fit into the power outlet only one way. If you are unable to insert the plug fully into the outlet, contact your dealer.
- Unplug the unit from the wall (mains) outlet when not in use for a long time. To disconnect the cord (mains lead), pull it out by the plug. Never pull the cord itself.
- Do not operate the unit with a damaged cord or if the unit has been dropped or damaged.
- Do not bend the AC power cord forcibly, or put a heavy object on it. This will damage the cord and may cause a fire or an electrical shock.
- Be sure that nothing metallic comes into contact with the metal parts of the connecting plate. If this happens, a short may occur and the unit may be damaged.
- Always keep the metal contacts clean.
- Do not disassemble the unit.
- Do not apply mechanical shock or drop the unit.
- While the unit is in use, particularly during charging, keep it away from AM receivers and video equipment because it will disturb AM reception and video operation.
- The unit becomes warm while in use. This is normal.
- Do not place the unit in locations that are:
  - Extremely hot or cold
  - Dusty or dirty
  - Very humid
  - Vibrating

If any difficulty should arise, unplug the unit and contact your nearest Sony dealer.

## Using Your Camcorder Abroad

Each country has its own electric and TV color systems. Before using your camcorder abroad, check the following points.

### Power Sources

You can use your camcorder in any country with the supplied AC power adaptor within 110 V to 240 V AC, 50/60 Hz.

Use a commercially available AC plug adaptor [a], if necessary, depending on the design of the wall outlet [b].

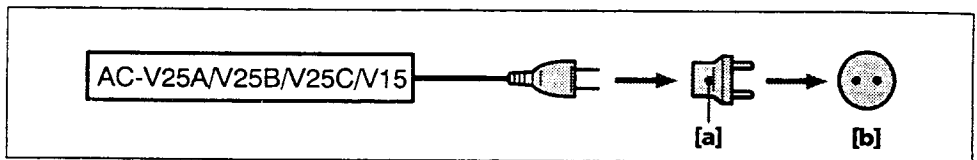

### Difference in Color Systems

This camcorder is an NTSC system based camcorder. If you want to view the playback picture on a TV, it must be an NTSC system based TV or a PAL-M system based TV with an NTSC/PAL-M transcoder. Check the following list.

#### NTSC system countries

Bahama Islands, Bolivia, Canada, Central America, Chile, Colombia, Ecuador, Jamaica, Japan, Korea, Mexico, Peru, Surinam, Taiwan, the Philippines, the U.S.A., Venezuela, etc.

#### PAL system countries

Australia, Austria, Belgium, China, Denmark, Finland, Germany, Great Britain, Holland, Hong Kong, Italy, Kuwait, Malaysia, New Zealand, Norway, Portugal, Singapore, Spain, Sweden, Switzerland, Thailand, etc.

#### PAL-M system country

Brazil

#### PAL-N system countries

Argentina, Paraguay, Uruguay

#### SECAM system countries

Bulgaria, Czech Republic, France, Guiana, Hungary, Iran, Iraq, Monaco, Poland, Russia, Slovak Republic, Ukraine, etc.

# Trouble Check

If you run into any problem using the camcorder, use the following table to troubleshoot the problem. Should the difficulty persist, disconnect the power source and contact your Sony dealer or local authorized Sony service facility.

## Camcorder

	Symptom	Cause	Corrective Actions	Page
Power	The power is not on.	The battery pack is not attached.	Attach the battery pack.	8
		The battery is dead.	Use a charged battery pack.	6
		The AC power adaptor is not connected to a wall outlet.	Connect the AC power adaptor to a wall outlet.	18
	The power goes off.	While being operated in CAMERA mode, the camcorder has been in the Standby mode for more than 5 minutes.	Turn STANDBY down once and turn it up again.	11
		The battery is dead.	Use a charged battery pack.	6
	The battery pack is quickly discharged.	The ambient temperature is too low.	—	36
		The battery pack has not been charged fully.	Charge the battery pack again.	6
		The battery pack is completely dead, and cannot be recharged.	Use another battery pack.	37
	The beep sounds when the battery is attached.	The battery is discharged during a long period of storage.	Charge the battery pack again.	6
	Operation	START/STOP does not operate.	The tape is stuck to the drum.	Eject the tape.
The tape has run out.			Rewind the tape or use a new one.	16
The POWER switch is set to VTR.			Set it to CAMERA.	10
The tab on the cassette is out (red).			Use a new tape or slide the tab.	9
The cassette cannot be removed from the holder.		The battery is dead.	Use a charged battery pack or the AC power adaptor.	6 18
No function except for cassette ejection works.		Moisture condensation has occurred.	Remove the cassette and leave the camcorder for at least an hour.	39
The date or time indicator is flashing.		You pressed DATE and TIME together for more than 2 seconds.	The camcorder is not malfunctioning. You may start recording. Flashing will stop soon.	—
The tape does not move when a tape transport button is pressed.		The POWER switch is set to CAMERA or OFF.	Set it to VTR.	16
		The tape has run out.	Rewind the tape or use a new one.	16

Additional Information

(to be continued)

## Trouble Check

	Symptom	Cause	Corrective Actions	Page
Operation	The STEADY SHOT function does not activate. (CCD-TR600 only)	STEADY SHOT is set to OFF.	Set STEADY SHOT to ON.	25
	No sound or only a low sound is heard when playing back a tape.	The stereo tape is played back with HiFi SND set to "1" or "2" in the menu system.	Set to "STEREO" in the menu system.	31
	Excessive high-pitched sound is heard.	The picture has been recorded with WIND set to ON in the menu system.	When there is no wind, set the selector to OFF.	31
	Recording stops in a few seconds.	REC TIME switch is set to 5 SEC.	Set it to NORMAL.	29
	The date or time indicator disappears.	—	Reset the date and time.	35
Picture	The image on the viewfinder screen is not clear.	The viewfinder lens is not adjusted.	Adjust the viewfinder lens.	11
	A vertical band appears when a subject such as lights or a candle flame is shot against a dark background.	The contrast between the subject and background is too high.	The camcorder is not malfunctioning. Change locations.	—
	The menu is not displayed on the TV.	DISPLAY on the Remote Commander has not been pressed.	Press DISPLAY on the Remote Commander.	17
	The playback picture is not clear.	EDIT is set to ON in the menu system.	Set it to OFF.	31
	The picture is "noisy."	The video heads may be dirty.	Clean the heads using the Sony V8-25CLH cleaning cassette.	40
	An unknown picture is displayed.	The camcorder operates in Demo mode.	Exit the Demo mode.	51
Others	The supplied Remote Commander does not work.	COMMANDER is set to OFF in the menu system.	Set it to ON.	30
		Something is blocking the infrared rays.	Remove the obstacle.	—
		The battery is not inserted with the correct polarity.	Insert the battery with the correct polarity.	50
		The batteries are dead.	Insert new ones.	50
	There is dust in the viewfinder.	—	Remove the viewfinder barrel and clean the viewfinder screen or viewfinder lens. (CCD-TR100 only)	40

## AC Power Adaptor

	Symptom	Cause	Corrective Actions	Page
AC power adaptor	The POWER lamp does not light.	—	Set the selector to the center position (AC-V25A / V25B / V25C only) and disconnect the power cord. After about one minute, reconnect the power cord and set the selector to CHARGE again.	8
	The CHARGE lamp flashes.	See the following chart.		

### When the CHARGE Lamp Flashes

Check through the following chart.

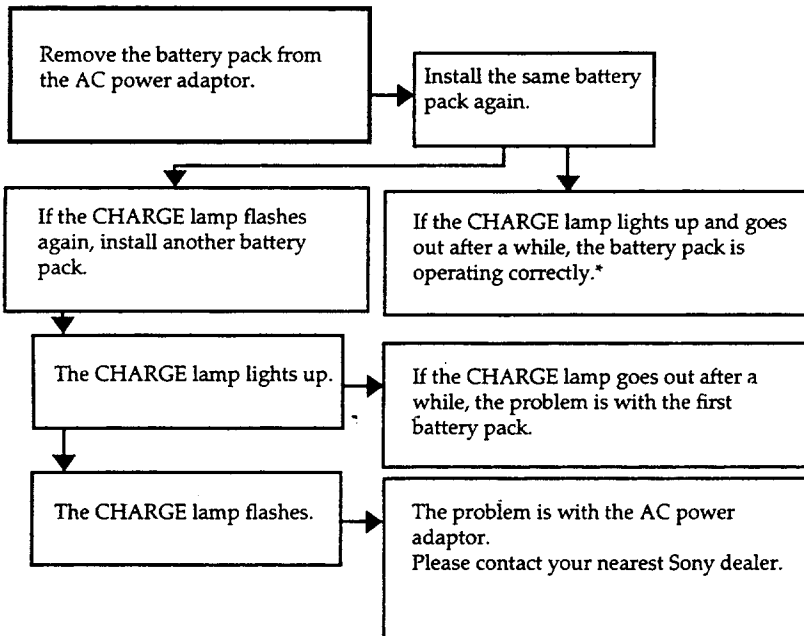

Additional Information

- \* If you use a battery pack which you have just bought or which has been left unused for a long time, the CHARGE lamp may flash at the first charging. This does not indicate a problem. Repeat again to charge with the same battery pack.



## Identifying the Parts

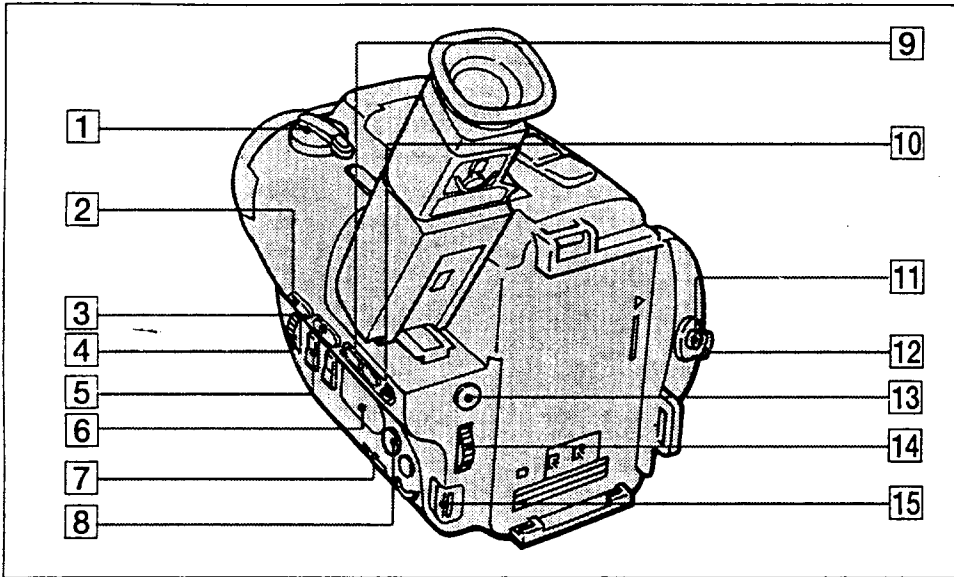

- |  |  |
|--|--|
| <b>1</b> POWER switch (p. 10, 16)      | <b>9</b> DATE and TIME buttons (p. 21)       |
| <b>2</b> FADER button (p. 23)          | <b>10</b> COUNTER RESET button (p. 11)       |
| <b>3</b> PROGRAM AE button (p. 22)     | <b>11</b> START/STOP button (p. 10)          |
| <b>4</b> Focus dial (p. 24)            | <b>12</b> STANDBY switch (p. 10)             |
| <b>5</b> FOCUS switch (p. 24)          | <b>13</b> MENU button (p. 30)                |
| <b>6</b> Display window (p. 52)        | <b>14</b> Menu dial (p. 30)                  |
| <b>7</b> REC TIME switch (p. 29)       | <b>15</b> BATT (battery release) knob (p. 8) |
| <b>8</b> PICTURE EFFECT button (p. 27) |  |

Additional Information



## Identifying the Parts

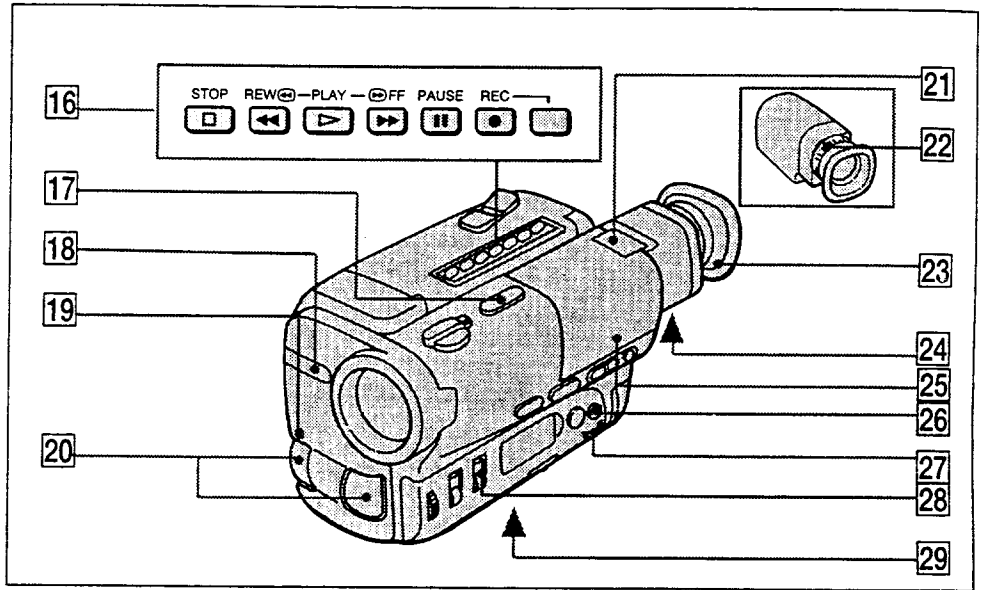

- |  |  |
|--|--|
| <p><b>16</b> Tape transport buttons (p. 16)</p> <ul style="list-style-type: none"> <li>□ STOP (stop)</li> <li>◀ REW (rewind)</li> <li>▶ PLAY (playback)</li> <li>▶▶ FF (fastforward)</li> <li>   PAUSE (pause)</li> <li>● REC (recording)</li> </ul> <p><b>17</b> EDITSEARCH button (p. 14)</p> <p><b>18</b> Remote sensor (p. 51)<br/>Aim the Remote Commander here for remote control.</p> <p><b>19</b> Camera recording/battery lamp</p> <p><b>20</b> Built in microphone</p> <p><b>21</b> Lighting aperture (CCD-TR600 only)</p> | <p><b>22</b> Viewfinder lens adjustment ring (CCD-TR100 only) (p. 11)</p> <p><b>23</b> Eyecup</p> <p><b>24</b> Viewfinder lens adjustment lever (CCD-TR600 only) (p. 11)</p> <p><b>25</b> Viewfinder (p. 11)</p> <p><b>26</b> EXPOSURE button (p. 28)</p> <p><b>27</b> Exposure dial (p. 28)</p> <p><b>28</b> STEADY SHOT switch (CCD-TR600 only) (p. 25)</p> <p><b>29</b> Tripod receptacle (p. 13)</p> |
|--|--|



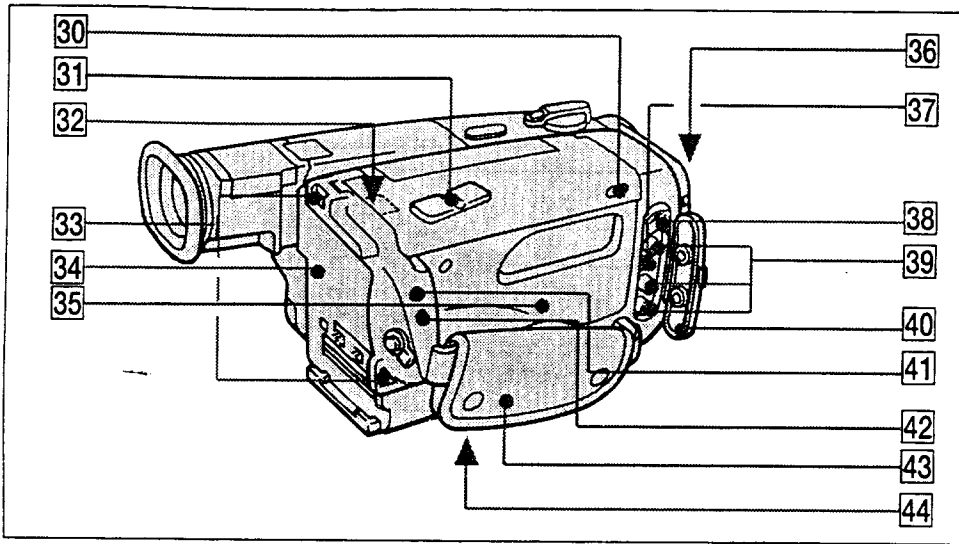

- 30** Cassette compartment lid release knob (p. 9)
- 31** Power zoom button (p. 12)
- 32** Eject button (under the cover) (p. 9)
- 33** Hooks for shoulder strap (See below.)
- 34** Battery mounting surface (p. 8)
- 35** Cassette compartment (p. 9)
- 36** MIC jack (PLUG IN POWER)  
Connect an external microphone (not supplied). This jack also accepts a "plug-in-power" microphone.
- 37** RFU DC OUT (RFU adaptor DC output) jack
- 38** S VIDEO jack (p. 15)
- 39** Audio/Video jacks (p. 15)
- 40** Jack cover
- 41** LANC control jack  
☛ stands for Local Application Control Bus System. The ☛ control jack is used for controlling the tape transport of video equipment and peripherals connected to it. This jack has the same function as the jack indicated as CONTROL L or REMOTE.
- 42** ☞ (Headphones) jack
- 43** Grip strap (p. 13)
- 44** Lithium battery compartment (p. 34)

Additional Information

### Attaching the Shoulder Strap

Attach the supplied shoulder strap to the hooks for the shoulder strap ( **33** ).

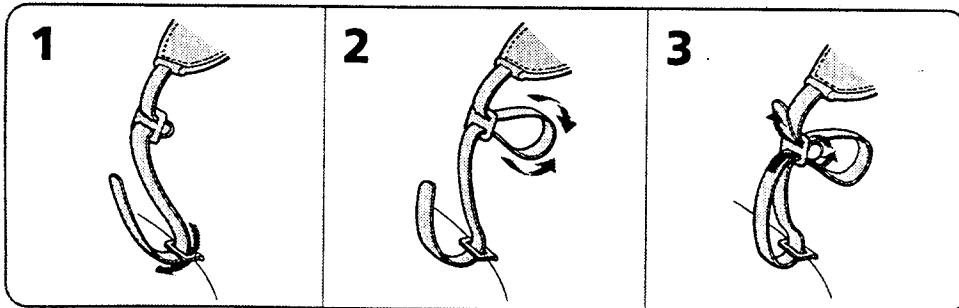

## Identifying the Parts

### Remote Commander

The buttons that have the same name on the Remote Commander as on the camcorder function identically.

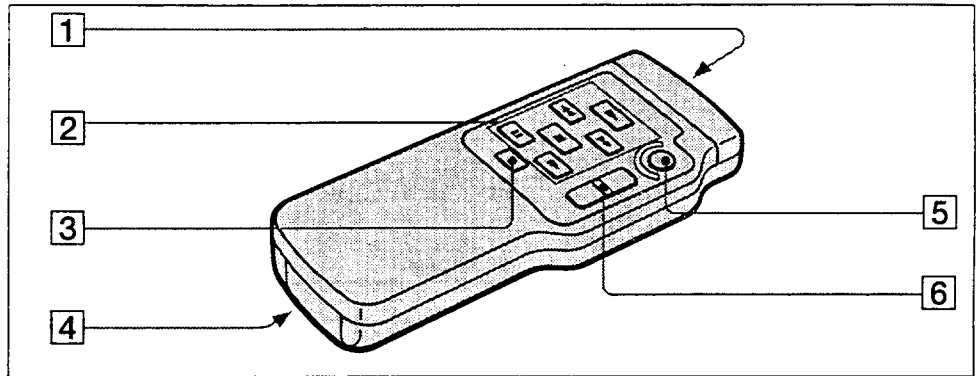

- |   |  |
|---|--|
| <b>1 Transmitter</b><br>Point toward the remote sensor to control the camcorder after turning on the POWER switch on the camcorder. | <b>4 Size AA (R6) battery holder</b>   |
| <b>2 Tape transport buttons</b>   | <b>5 START/STOP button</b>   |
| <b>3 DISPLAY button</b>   | <b>6 Power zoom button</b><br>The zooming speed is unchangeable in the Remote Commander. |

### To Prepare the Remote Commander

To use the Remote Commander, you must insert two size AA (R6) batteries. Use the supplied size AA (R6) batteries.

- (1) Remove the battery cover from the Remote Commander.
- (2) Insert both of the size AA (R6) batteries with correct polarity.
- (3) Put the battery cover back onto the Remote Commander.

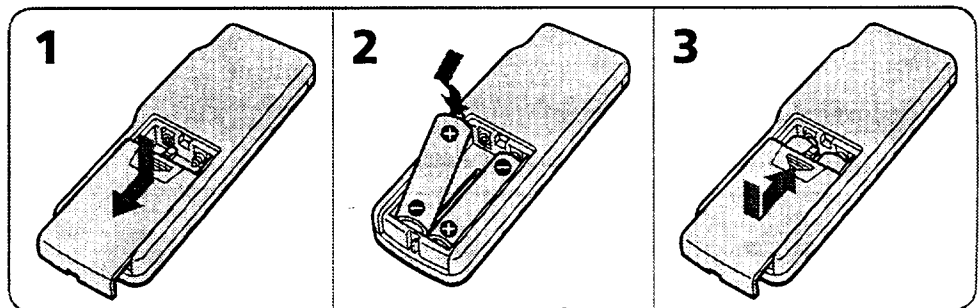

### Note on battery life

The batteries for the Remote Commander last about 6 months under normal operation. When the batteries become weak or dead, the Remote Commander does not work.

### To avoid damage from possible battery leakage

Remove the batteries when you will not use the Remote Commander for a long time.

## To Use the Remote Commander

Make sure that the COMMANDER mode is set to ON in the menu system.

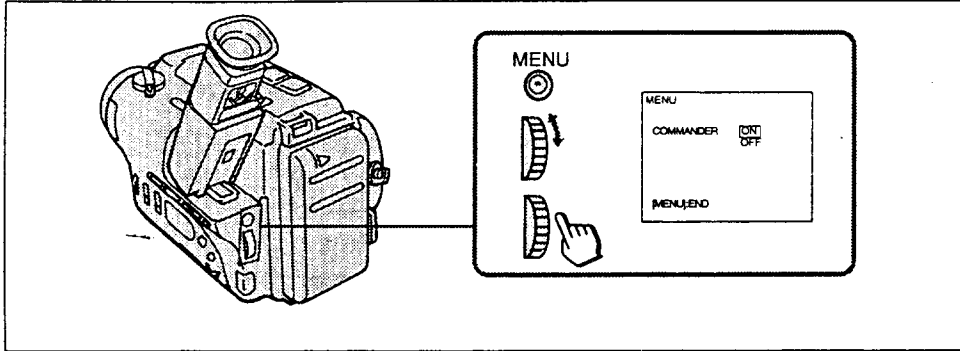

## Remote Control Direction

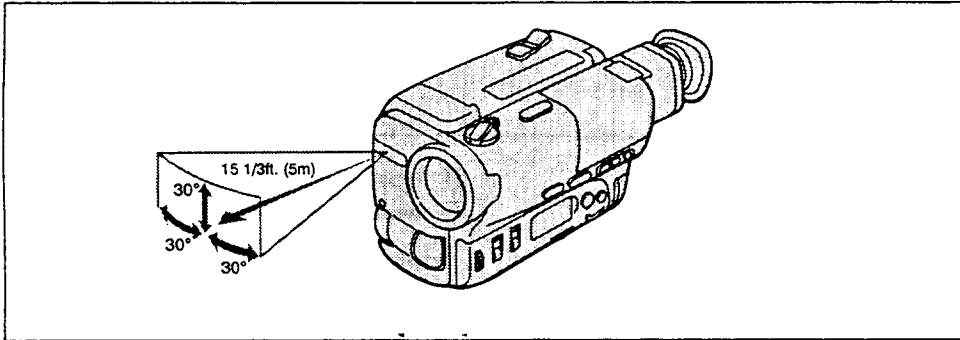

## Notes on the Remote Commander

- Keep the remote sensor away from strong light sources such as direct sunlight or illumination. Otherwise, the remote control may not be effective.
- Be sure that there is no obstacle between the remote sensor and the Remote Commander.
- This camcorder works at commander mode VTR 2. The commander modes (1, 2 and 3) are used to distinguish this camcorder from other Sony VCRs to avoid remote control misoperation. If you use another Sony VCR at commander mode VTR 2, we recommend you change the commander mode or cover the remote sensor of the VCR with black paper.

## To Watch the Demonstration

You can watch a brief demonstration of pictures with special effects.

If the demonstration appears when you turn on the camcorder for the first time, exit the Demo mode to use your camcorder.

**To enter Demo mode,** (1) Eject the cassette and turn the POWER switch to OFF. (2) Turn STANDBY up. (3) While holding down  $\blacktriangleright$ , turn the POWER switch to CAMERA. Demonstration starts. The demonstration stops when you insert the cassette.

Note that once you enter Demo mode, this mode is retained as long as the lithium battery is in place. Therefore, demonstration starts automatically 10 minutes later everytime you turn the POWER switch to CAMERA, or after you eject the cassette.

**To exit Demo mode,** (1) Turn the POWER switch to OFF. (2) Turn STANDBY up. (3) While holding down  $\square$ , turn the POWER switch to CAMERA.

# Identifying the Parts

## Operation Indicators

For details on each indicator, refer to the pages indicated in the parentheses.

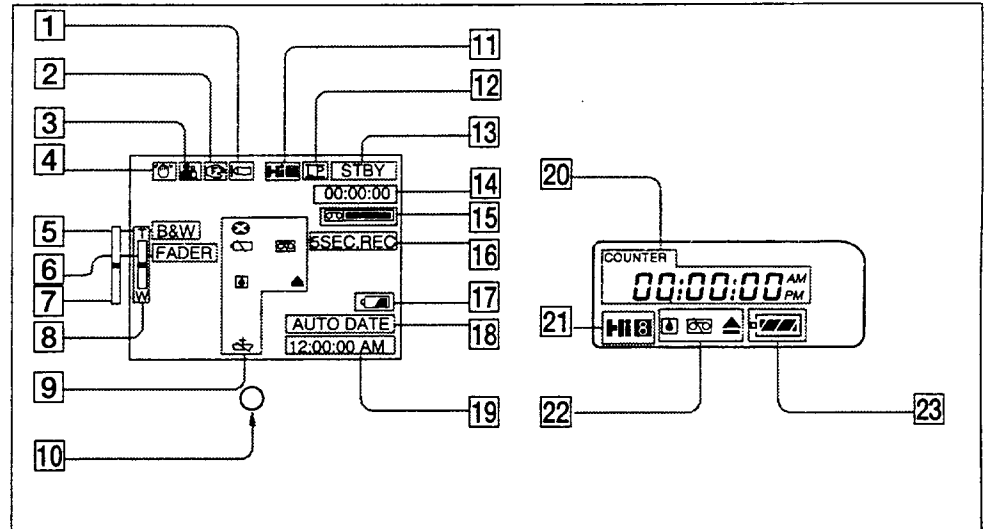

- 1 WIND indicator (p. 31)
- 2 Manual focusing (p. 24)
- 3 PROGRAM AE indicator (p. 22)
- 4 Steady shot indicator (CCD-TR600 only) (p. 25)
- 5 PICTURE EFFECT indicator (p. 27)
- 6 FADER indicator (p. 23)
- 7 Exposure indicator (p. 28)
- 8 Power zoom indicator (p. 12)
- 9 Warning indicators (p. 53)
- 10 Recording lamp/Battery lamp
- 11 Playing back or recording in Hi8 format
- 12 Lights up when playing back a tape recorded in LP mode.
- 13 Tape transport mode

- 14 Tape counter (P. 11)
- 15 Remaining tape indicator

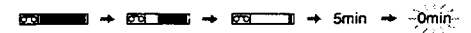

- 16 5-Second recording indicator (p. 29)
- 17 Remaining battery indicator (p. 37)



- 18 AUTO DATE indicator (p. 10)
- 19 Date or time indicator (p. 21)
- 20 Tape counter (p. 11)
- 21 Playing back or recording in Hi8 format
- 22 Warning indicator (p. 53)
- 23 Remaining battery indicator (p. 37)



# Warning Indicators

If indicators flash in the viewfinder or in the display window, check the following:  
 ♪: you can hear the beep sound when the BEEP is set to ON.

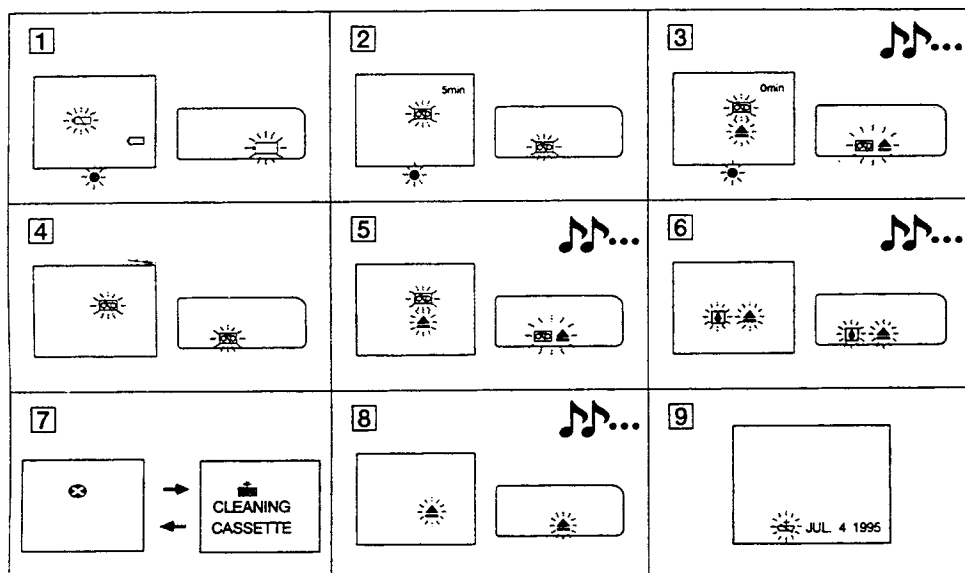

- 1 The battery is weak or dead.**  
 Slow flashing: The battery is weak.  
 Fast flashing: The battery is dead.
- 2 The tape is near the end.**  
 The flashing is slow.
- 3 The tape has run out.**  
 The flashing becomes rapid.
- 4 No tape has been inserted.**
- 5 The tab on the tape is out (red).**
- 6 Moisture condensation has occurred** (p. 39).
- 7 The video heads may be contaminated** (p. 40).  
 This indicator appears only on the viewfinder.
- 8 Some other trouble has occurred.**  
 Disconnect the power source and contact your Sony dealer or local authorized facility.
- 9 The lithium battery is weak or is not installed** (p. 34).

Additional Information

# Index

## A

AC power adaptor .....	6, 18
Adjusting viewfinder .....	11
AFM Hi-Fi Sound .....	36
AUTO DATE .....	11
Auto focus .....	25
A/V connecting cable .....	15

## B

Battery pack .....	6
BEEP .....	11

## C

Camera recording .....	10
Car battery .....	20
Charging battery .....	6
Cleaning video heads .....	40
Clock set .....	35
Connection .....	15
COUNTER RESET .....	11

## D, E

DATE/TIME .....	21
DEMO .....	51
Digital zoom .....	12
DISPLAY .....	17
EDIT .....	32
Editing .....	32
EDITSEARCH .....	14
EJECT .....	9
EXPOSURE .....	28

## F, G, H

Fade-in/Fade-out .....	23
FADER .....	23
Fastforward .....	16
High-speed shutter mode .....	22

## I, J, K, L

LANC .....	49
Lithium battery .....	34

## M, N, O, P

Manual focus .....	24
Menu system .....	30
M. FADER .....	23
MIC (microphone) jack .....	49
PICTURE EFFECT .....	27
Playback on TV .....	16
Playback pause .....	17
Portrait mode .....	22
Power sources .....	18
Power zoom .....	12
PROGRAM AE .....	22
PUSH AUTO .....	25

## Q, R

Rec review .....	14
REC TIME .....	29
Remote Commander .....	50
Remote control jack .....	49
Rewind .....	16

## S

Shoulder strap .....	49
Skip scan .....	17
Sports mode .....	22
STANDBY .....	10
Standby mode .....	10
STEADY SHOT .....	25
Supplied accessories .....	5

## T, U, V

Tape counter .....	11, 52
Tripod mounting .....	13
Trouble check .....	43
Twilight mode .....	22

## W, X, Y, Z

WIND .....	31
Zoom .....	12

ny Corporation Printed in Japan